

## **RESOLUTION NO. 2806**

### **A RESOLUTION OF THE CITY OF WILSONVILLE AUTHORIZING THE CITY MANAGER TO EXECUTE THE FIRST AMENDMENT TO CONSTRUCTION CONTRACT WITH MOORE EXCAVATION, INC. FOR THE GARDEN ACRES ROAD & PLM\_1.2 WATER TRANSMISSION LINE PROJECT.**

WHEREAS, the City has planned, designed, and budgeted for the completion of Capital Improvement Project #1127, 2103, 4201, and 7061, known as the Garden Acres Road and PLM\_1.2 Water Transmission Line project (the Project); and

WHEREAS, the City entered into an intergovernmental agreement (Resolution No. 2743) with Tualatin Valley Water District and the City of Hillsboro, collectively doing business and referred to herein as the Willamette Water Supply Program (WWSP), to jointly design and construct the Garden Acres Road project and Willamette Water Supply PLM\_1.2 Garden Acres to 124<sup>th</sup> Pipeline project; and

WHEREAS, the City authorized a Construction Contract (Resolution No. 2757) with Moore Excavation, Inc. (“Contractor”) to construct the Project in the amount of \$10,782,928.00 on June 17, 2019; and

WHEREAS, the Construction Contract is between the City and the Contractor, and the City is responsible for overall management and administration of the joint construction project; and

WHEREAS, pursuant to an Intergovernmental Agreement between the City and WWSP, WWSP will reimburse the City for all costs associated with construction, construction management, and administration of the PLM\_1.2 Water Transmission Line portion of the Project as part of the joint construction project; and

WHEREAS, WWSP desires to connect the PLM\_1.2 Water Transmission Line to the PLM\_3.0 Water Transmission Line (Added Work) as part of the Project and has negotiated an acceptable price with Moore Excavation, Inc.; and

WHEREAS, the City desires to amend the Construction Contract with Moore Excavation, Inc. to construct the Added Work described above, at WWSP’s sole cost.

NOW, THEREFORE, THE CITY OF WILSONVILLE RESOLVES AS FOLLOWS:

1. The procurement process for the Project duly followed Oregon Public Contracting Rules, and Moore Excavation, Inc. has provided an acceptable cost proposal to construct the Added Work.
2. The City of Wilsonville, acting as the Local Contract Review Board, authorizes the City Manager to enter into and execute, on behalf of the City of Wilsonville, a Construction Contract amendment with Moore Excavation, Inc. for a stated value of \$2,157,060.00.
3. The Amendment will also incorporate two earlier Change Orders to the Construction Contract (totaling \$73,671.83). The Change Orders, which include changes to be paid in part by the City (\$50,794.72) and in part by WWSP (\$22,877.11), plus the additional \$2,157,060 to be paid solely by WWSP, bring the amended Construction Contract total to \$13,013,659.83.
4. In order to allow future change orders, if needed, to occur in the field without having to come back to City Council, the authorized Construction Contract total is hereby adjusted to up to \$14,557,427.20, allowing for continued Contracting Agency approval of change orders and contract amendments that exceed this adjusted amount by fifteen percent (15%), in accordance with City Code requirement.
5. This Resolution becomes effective upon adoption.

ADOPTED by the Wilsonville City Council at a regular meeting thereof this 20<sup>th</sup> day of April 2020, and filed with the Wilsonville City Recorder this date.

DocuSigned by:  
  
C2B6698B3949461...  
TIM KNAPP, MAYOR

ATTEST:

DocuSigned by:  
  
E784DE10276B498...  
Kimberly Veliz, City Recorder

**SUMMARY OF VOTES:**

Mayor Knapp

Council President Akervall

Councilor Lehan

Councilor West

Councilor Linville

**EXHIBIT:**

- A. First Amendment to Garden Acres Road and PLM\_1.2 Water Transmission Line Construction Contract

**CITY OF WILSONVILLE**  
**FIRST AMENDMENT TO CONSTRUCTION CONTRACT (CIP# 4201)**  
**Moore Excavation, Inc. – Garden Acres Road and Pipeline Project**

This is the First Amendment to the City of Wilsonville Construction Contract (CIP# 4201) between the City of Wilsonville (City) and Moore Excavation, Inc., dated June 27, 2019 (“First Amendment”). This First Amendment is effective on April \_\_\_\_\_, 2020 (“Effective Date”).

**FIRST AMENDMENT**

**Section 1. Previous Contract Change Orders**

Since construction began, the City and Contractor have agreed to and issued Change Order No. 1 for \$8,882.64 and Change Order No. 2 for \$64,789.19. Change Order No. 2 added an additional six (6) days to the time of Contract completion. These Change Orders are already in effect and are incorporated by reference herein.

**Section 2. Additional Work**

Although the Contract is between the City and Contractor, Work under the Contract is also being performed on behalf of the Willamette Water Supply Program (WWSP). WWSP has requested additional Work in the amount of \$2,157,060 (“Additional WWSP Work”). The Scope of Work for the Additional WWSP Work is attached hereto as **Exhibit 1** (which includes labels of Exhibits A through C). Because of the amount of this Additional WWSP Work that is being added to this Contract, under City public contracting rules, the City must obtain City Council approval to add the sum for the Additional WWSP Work to the City Contract.

**Section 3. New Contract Amount**

Combining the two already approved Change Orders, along with the Additional WWSP Work, the Contract Sum is hereby amended to a total sum of THIRTEEN MILLION THIRTEEN THOUSAND SIX HUNDRED FIFTY-NINE DOLLARS AND EIGHTY-THREE CENTS (\$13,013,659.83).

**Section 4. Additional Time**

Four (4) days will be added to the Contract Term, for both Substantial Completion and Final Completion to accommodate this Additional WWSP Work. These four (4) days are in addition to the six (6) days already added by Change Order No. 2.

**Section 5 Other Contract Provisions**

Except as provided herein, all other provisions of the Contract remain as written.

**CONTRACTOR:**

MOORE EXCAVATION, INC.

By: \_\_\_\_\_

Print Name: \_\_\_\_\_

As Its: \_\_\_\_\_

Employer I.D. No. 93-0583943

**CITY:**

CITY OF WILSONVILLE

By: \_\_\_\_\_

Print Name: \_\_\_\_\_

As Its: \_\_\_\_\_

APPROVED AS TO FORM:

\_\_\_\_\_  
Barbara A. Jacobson, City Attorney  
City of Wilsonville, Oregon

ACCEPTED AND AGREED TO BY:

WILLAMETTE WATER SUPPLY PROGRAM

By: \_\_\_\_\_

Dave Kraska

As Its: Director

Exhibit A - Contract Amendment #01  
Pay Item Adjustment

**New Pay Items**

ITEM	ITEM DESCRIPTION	UNIT	UNIT COST	QUANTITY	COST
B-300	Moblilization and Demobilization Sta.310+80.00 to Sta. 315+56.24	LS	\$ 42,000.00	1	\$ 42,000.00
B-301	Construction Entrance near Sta. 314+00	LS	\$ 12,250.00	1	\$ 12,250.00
B-302	Health and Safety Sta.310+80.00 to Sta. 315+56.24	LS	\$ 5,000.00	1	\$ 5,000.00
B-303	Erosion Control Sta.310+80.00 to Sta. 315+56.24	LS	\$ 30,000.00	1	\$ 30,000.00
B-304	Sediment Fencing Sta.310+80.00 to Sta. 315+56.24	LS	\$ 4,000.00	1	\$ 4,000.00
B-305	Tree Protection Fence Sta.310+80.00 to Sta. 315+56.24	LS	\$ 400.00	1	\$ 400.00
B-306	Clearing and Grubbing Sta.310+80.00 to Sta. 315+56.24	LS	\$ 41,000.00	1	\$ 41,000.00
B-307	Construction Survey Work Sta.310+80.00 to Sta. 315+56.24	LS	\$ 66,000.00	1	\$ 66,000.00
B-308	Geotechnical Consultant Sta.310+80.00 to Sta. 315+56.24	LS	\$ 37,000.00	1	\$ 37,000.00
B-309	Furnish 66-inch ID MLPCSP, Welded Steel Pipe, min t=0.313-inch wall Sta.310+80.00 to Sta. 315+56.24	LS	\$ 370,000.00	1	\$ 370,000.00
B-310	Install of 66-inch ID MLPCSP, Welded Steel Pipe, min t=0.313-inch wall Sta. 310+80.00 to Sta. 311+28.00 and Sta. 312+73 to Sta. 315+56.24	LS	\$ 237,600.00	1	\$ 237,600.00
B-311	Blowoff – Type I Sta. 315+45.00	LS	\$ 40,000.00	1	\$ 40,000.00
B-312	Trench Cutoff Walls between Sta.310+80.00 to Sta. 315+56.24	LS	\$ 15,000.00	1	\$ 15,000.00
B-313	Trenchless Launch Shaft (North Shaft)	LS	\$ 255,000.00	1	\$ 255,000.00
B-314	Trenchless Reception Shaft (South Shaft)	LS	\$ 176,000.00	1	\$ 176,000.00
B-315	80-inch (min) ID Casing Sta. 311+28.00 to Sta. 312+73, Trenchless Crossing, and Installation of 66-inch Pipe in Casing	LS	\$ 710,000.00	1	\$ 710,000.00
B-316	PLM 1.2 to PLM 3.0 Closure Spool	LS	\$ 44,000.00	1	\$ 44,000.00
B-317	Cathodic Protection System between Sta.310+80.00 to Sta. 315+56.24	LS	\$ 28,000.00	1	\$ 28,000.00
B-318	Pipeline Cleaning and Testing between Sta.310+80.00 to Sta. 315+56.24	LS	\$ 19,000.00	1	\$ 19,000.00
B-319	Traffic Control between Sta.310+80.00 to Sta. 315+56.24	LS	\$ 18,000.00	1	\$ 18,000.00
B-320	3/4"-0 Aggregate Base Sta.310+80.00 to Sta. 315+56.24	LS	\$ 4,410.00	1	\$ 4,410.00
B-321	Level 3, 1/2 Inch ACP Mixture Sta.310+80.00 to Sta. 315+56.24	LS	\$ 2,400.00	1	\$ 2,400.00
<b>Total</b>					<b>\$ 2,157,060.00</b>

**Fund Estimate Amendment**

FUND NUMBER		CURRENT ESTIMATE	AMENDED ESTIMATE	CHANGE
#2103-30	Garden Acres Sewer Extension	\$ 1,249,990.78	\$ 1,249,990.78	\$ -
#4201-39	Garden Acres Road Improvement	\$ 3,859,390.01	\$ 3,859,390.01	\$ -
#4201-80	WWSP Pipeline & Garden Acres Share	\$ 5,133,690.08	\$ 7,290,750.08	\$ 2,157,060.00
#7061-30	Garden Acres Offsite Storm System	\$ 613,528.96	\$ 613,528.96	\$ -
<b>Total</b>		<b>\$ 10,856,599.83</b>	<b>\$ 13,013,659.83</b>	<b>\$ 2,157,060.00</b>



**Exhibit B - Contract Amendment #01**  
**Pay Item Detailed Description**  
**Garden Acres / PLM\_1.2**

SECTION 01 22 13 - UNIT PRICE MEASUREMENT AND PAYMENT, Paragraph 1.3 after the last item on page III-126 as previously amended ADD:

No.	Item	Description	Measurement	Payment
B-200	Mobilization and Demobilization Sta. 310+80.00 to Sta. 315+56.24	The item shall include all costs for preparing for construction activities between Sta. 310+80 to 513+56.24. These costs may include, but are not limited to: moving equipment to the project site, moving personnel and supplies, acquiring bonds and submitting them to the City for approval, submitting certificates of insurance acceptable to the City, applying for and securing local permits as may be required, setting up administrative items, pre-construction meetings, and other preparatory activities associated with the project. This item also includes materials, labor, and equipment to install private property temporary fencing; complete site restoration; and other incidentals to complete work between Sta. 310+80 through 315+56.24 as shown on the drawings.	Measurement for this item will be Lump Sum based on 50% after completion of mobilization and 50% after demobilization.	Payment shall on 50% after completion of mobilization and 50% after demobilization.
B-201	Construction Entrance near Sta. 314+00	The Lump sum price shall include all costs for materials, equipment and labor to install the gravel construction entrance as shown on the approved plans. This also includes any and all maintenance required to keep the entrance in proper condition to perform as designed and restoration as shown on the drawings after construction completion.	Measurement for this item will be Lump Sum based on the percent complete for this item during the period for each monthly progress payment.	Payment shall be made based on the percent of work complete.
B-202	Health and Safety Sta. 310+80.00 to Sta. 315+56.24	Lump sum price includes labor, equipment, and materials necessary to prepare, implement, monitor, and modify (as necessary) the Health and Safety Plan; attend Owner's health and safety meetings; participation in Owner's safety orientation training; placing a full-time health and safety representative on-site; and preparing <u>required monitoring reports</u> .	Measurement for this item will be based on the percent of work complete (percentage of total activities complete) during the period for each monthly progress payment.	Payment shall be made based on the percent of work complete.
B-203	Erosion Control Sta. 310+80.00 to Sta. 315+56.24	The Lump sum price shall include all cost for materials, equipment, and labor to install, maintain, and remove the erosion control for the project between Sta. 310+80.00 to Sta. 315+56.24. This lump sum price includes restoration per Plan and Profile Drawings.	Measurement for this item will be based on the percent of work complete (percentage of total activities complete) during the period for each monthly progress payment.	Payment shall be made based on the percent of work complete.
B-204	Sediment Fencing Sta. 310+80.00 to Sta. 315+56.24	The Lump sum price shall include all cost for materials, equipment, and labor to install sediment fencing as shown on the drawings. This includes the maintenance during construction to keep the fence performing as designed and remove after completion of construction.	Measurement for this item will be Lump Sum based on the percent complete for this item during the period for each monthly progress payment.	Payment shall be made based on the percent of work complete.



No.	Item	Description	Measurement	Payment
B-205	Tree Protection Fence Sta. 310+80.00 to Sta. 315+56.24	The Lump sum price shall include all cost for materials, equipment, and labor to install tree protection fence. This includes the maintenance during construction to keep the fence performing as designed and remove after completion of construction.	Measurement for this item will be based on the percent of work complete (percentage of total activities complete) during the period for each monthly progress payment.	Payment shall be made based on the percent of work complete.
B-206	Clearing and Grubbing Sta. 310+80.00 to Sta. 315+56.24	The Lump sum price shall include all cost for materials, equipment, and labor for clearing and grubbing as defined in section 00320 of the specifications and Design Clarification No. 4.	Measurement for this item will be Lump Sum based on the percent complete for this item during the period for each monthly progress payment.	Payment shall be made based on the percent of work complete.
B-207	Construction Survey Work Sta. 310+80.00 to Sta. 315+56.24	The Lump sum price shall include all cost for materials, equipment, and labor to provide Construction Survey Work per section 00305 and 01 73 23 of the specifications.	Measurement for this item will be based on the percent of work complete (percentage of total activities complete) during the period for each monthly progress payment.	Payment shall be made based on the percent of work complete.
B-208	Geotechnical Consultant Sta. 310+80.00 to Sta. 315+56.24	The Lump Sum price shall include all costs for materials, equipment and labor to design, monitor, maintain, and remove (as applicable) shaft shoring system; design and monitor the trenchless crossing; and all other activities per Design Clarification #4 for work between Sta. 310+80.00 to Sta. 315+56.24.	Measurement for this item will be Lump Sum based on the percent complete for this item during the period for each monthly progress payment.	Payment shall be made based on the percent of work complete.
B-209	Furnish 66-inch ID MLPCSP, Welded Steel Pipe, min t=0.313-inch wall Sta. 310+80.00 to Sta. 315+56.24	The Lump Sum price includes, but not limited to, furnishing 66-inch Nominal ID steel pipe, fittings, and dished heads, cement mortar-lined and polyurethane-coated, with pipe wall thickness as shown on the Plans.	Measurement for this item will be Lump Sum based on the percent complete for this item during the period for each monthly progress payment.	Payment shall be made based on the percent of work complete.

No.	Item	Description	Measurement	Payment
B-210	Install of 66-inch ID MLPCSP, Welded Steel Pipe, min t=0.313-inch wall Sta. 310+80.00 to Sta. 311+28.00 and Sta. 312+73 to Sta. 315+56.24	<p>The Lump Sum price includes, but not limited to, furnishing all materials (excluding pipe), equipment, labor, and incidentals for construction and installation of the 66-inch pipe, complete in accordance with the Contract Documents, including, offloading and temporary storage, joint welding, welding leads, and quality control testing, bends, outlets, fittings, common excavation, bedding, backfill, dewatering, compaction, cathodic protection system joint bonding and heat shrinkable polyolefin coatings, finishing interior and exterior joints, pipe locator ribbon and locate wires along the transmission pipeline, trench shoring design and systems, record drawings, locating and potholing of utilities crossing pipeline, protection and support of adjacent and crossing utilities. Furnish and install all applicable hardware including, but not limited to, nuts, bolts, washers, gaskets and isolation kits for a complete pipe installation.</p> <p>This Lump sum price also includes furnishing all materials, labor, and incidentals to install, test, and certify the pipe locate system, including assemblies, wiring, connections, and surface boxes. Furnish and install all pipe monumentation, including curb and markers posts for the stations indicated.</p>	Measurement for this item will be Lump Sum based on the percent complete for this item during the period for each monthly progress payment.	Payment shall be made based on the percent of work complete.
B-211	Blowoff – Type I Sta. 315+45.00	<p>The Lump Sum price includes furnishing all materials, equipment, labor, and incidentals for construction of Type I Blow-off; including; Flex- tend fitting, pipe, pipe installation, butterfly and gate valves, excavation, bedding, backfilling, compaction, testing, vault, cathodic protection and any other work and appurtenances needed to extend the discharge pipe from the tangential outlet connection to the blow-off structure, flange and bolts, complete, and any other work and appurtenances needed to construct the blow-off.</p>	Measurement for this item will be Lump Sum based on the percent complete for this item during the period for each monthly progress payment.	Payment shall be made based on the percent of work complete.
B-212	Trench Cutoff Walls between Sta. 310+80.00 to Sta. 315+56.24	<p>The Lump Sum price includes excavation beyond trench walls and bottom, furnishing and installing controlled low strength material (CLSM), within the bedding, pipe zone and trench zone, complete, as indicated on the Plans and details for all trench cutoff walls from Sta. 310+80.00 to Sta. 315+56.24.</p>	Measurement for this item will be Lump Sum based on the percent complete for this item during the period for each monthly progress payment.	Payment shall be made based on the percent of work complete.
B-213	Trenchless Launch Shaft (North Shaft)	<p>The Lump Sum price includes all materials, equipment, labor, and incidentals for the installation of launch shaft north of the Day Road, complete, including, but not limited to, excavation in soil, disposal of excess excavation material, shoring, instrumentation and monitoring, shaft construction, and bottom work slab (concrete) installation.</p> <p>This pay item also includes development of a dewatering plan and preparing submittals for review, implementation of the dewatering plan for trench less shafts and casing/piping installation, conducting required monitoring and testing of the water quality from the dewatering operation, disposal for all water removed from excavations, and performing all other work required for a complete system in accordance with the Contract Documents.</p>	Measurement for this item will be based on the percent of work complete (percentage of total activities complete) at the time of each monthly progress payment, as determined by the Owners.	Payment shall be made based on the percent of work complete.

No.	Item	Description	Measurement	Payment
B-214	Trenchless Reception Shaft (South Shaft)	<p>The Lump Sum price includes all materials, equipment, labor, and incidentals for the installation of the reception shaft south of the Day Road, complete, including, but not limited to, excavation in soil, disposal of excess excavation material, shoring, instrumentation and settlement monitoring, shaft construction, and bottom work slab (concrete) installation.</p> <p>This pay item also includes development of a dewatering plan and preparing submittals for review, implementation of the dewatering plan for trenchless shafts and casing/piping installation, conducting required monitoring and testing of the water quality from the dewatering operation, disposal for all water removed from excavations, and performing all other work required for a complete system in accordance with the Contract Documents.</p>	Measurement for this item will be based on the percent of work complete (percentage of total activities complete) at the time of each monthly progress payment, as determined by the Owners.	Payment shall be made based on the percent of work complete.
B-215	80-inch (min) ID Casing Sta. 311+28.00 to Sta. 312+73, Trenchless Crossing, and Installation of 66-inch Pipe in Casing	<p>Lump sum price includes all materials, equipment, labor, and incidentals for the tunneled crossing at Day Road, complete, including, but not limited to, trenchless construction, furnishing and installing the 80-inch ID (min), steel casing with wall thickness as specified under the road; casing pipe joint welding, trenchless construction method selection and plan; contractor-obtained permits; ventilation; spoils removal and disposal; noise-abatement compliance; dewatering, protection of adjacent utilities; contact grouting; records; and quality control testing.</p> <p>Lump sum price also includes furnishing all materials (excluding pipe), equipment, labor, and incidentals for installation of the 66-inch ID steel water transmission pipeline (carrier pipe) to be installed inside the casing, lined and coated, including, but not limited to, joint welding, and weld leads; placing the water transmission pipeline inside the casing, annular space grouting, casing spacers and end seals; furnishing and installing all applicable hardware for a complete pipe installation; record drawings; and quality control testing.</p> <p>This Lump sum price also includes furnishing all materials, labor, and incidentals to install, test, and certify the pipe locate system, including assemblies, wiring, connections, and surface boxes. Furnish and install all pipe monumentation, including curb and markers posts for the stations indicated.</p>	Measurement for this item will be based on the percent of work complete (percentage of total activities complete) at the time of each monthly progress payment, as determined by the Owners.	Payment shall be made based on the percent of work complete.
B-216	PLM 1.2 to PLM 3.0 Closure Spool	Lump sum price includes all materials, equipment, labor, and incidentals for all work required to excavate the trench between the dished heads, drain the pipeline as required to allow for removal of the dished head, remove the dished head, furnish and install a spool piece, furnish and install butt straps, repair the lining and coating at the joints, disinfect the spool piece, and backfill the trench.	Measurement for this item will be based on the percent of work complete at the time of each monthly progress payment, as determined by the Owners.	Payment shall be made based on the percent of work complete.

No.	Item	Description	Measurement	Payment
B-217	Cathodic Protection System between Sta. 310+80.00 to Sta. 315+56.24	Lump Sum Price includes furnishing, installing and testing the cathodic protection system, complete, including test stations, anodes, insulating kits, reference cells, thermite welds, appurtenances, boards, labeling, field measurements, commissioning, preparation and submittal of initial and final test results and reports and all other work to make the system functional for project work associated with Sta. 310+80.00 to Sta. 315+56.24.	Measurement for this item will be based on the percent of work complete (percentage of total activities complete) at the time of each monthly progress payment, as determined by the Owners.	Payment shall be made based on the percent of work complete.
B-218	Pipeline Cleaning and Testing between Sta. 310+80.00 to Sta. 315+56.24	Lump Sum Price includes all materials, equipment, labor, and incidentals for all work required to successfully clean, disinfect, and test the pipeline and appurtenances for project work associated with Sta. 310+80.00 to Sta. 315+56.24. Work includes, complete installation and removal of temporary bulkheads, cleaning debris from pipeline, supplying, treating, and discharging test water, hydrostatic pressure testing. Water quality testing and discharge and disposal, in compliance with permits, and draining the pipe in accordance with the specifications shall also	Measurement for this item will be based on the percent of work complete (percentage of total activities complete) at the time of each monthly progress payment, as determined by the Owners.	Payment shall be made based on the percent of work complete.
B-219	Traffic Control between Sta. 310+80.00 to Sta. 315+56.24	Lump Sum Price includes all materials, equipment, labor, and incidentals for coordination with local agencies and all work required for installation, maintenance, and removal of traffic control measures for project work associated with Sta. 310+80.00 to Sta. 315+56.24. This is inclusive of traffic controls permits and permit fee.	Measurement for this item will be based on the percent of work complete (percentage of total activities complete) at the time of each monthly progress payment, as determined by the Owners.	Payment shall be made based on the percent of work complete.
B-220	3/4"-0 Aggregate Base Sta. 310+80.00 to Sta. 315+56.24	The unit price item shall include all cost for materials, equipment, and labor to place and compact the Aggregate. The limits of this item are measured as the neat line to the back of the curb for project work associated with Sta. 310+80.00 to Sta. 315+56.24.	Measurement for this item will be based on field cubic yards.	Payment shall be made based unit price per \$40/CY.
B-221	Level 3, 1/2 Inch ACP Mixture Sta. 310+80.00 to Sta. 315+56.24	The unit price item shall include all cost for materials, equipment, and labor to place and compact the ACP for project work associated with Sta. 310+80.00 to Sta. 315+56.24.	Measurement for this item will be based on field tons.	Payment shall be made based on unit price \$98/TN.

**Exhibit C - Contract Amendment #01**  
**Plans & Specifications Modifications**  
**Garden Acres / PLM\_1.2**

SHEET INDEX		
SHEET NUMBER	DRAWING NUMBER	DESCRIPTION
<b>GENERAL</b>		
01	G-01	COVER SHEET
02	G-02	INDEX OF DRAWINGS
03	G-03	GENERAL LEGEND
04	G-04	GENERAL ABBREVIATIONS
05	G-05	OVERALL SITE PLAN
06	G-06	GEOTECHNICAL BOREHOLES PLAN
07	G-07	OVERALL PROFILE, APPURTENANCES, AND GENERAL NOTES
08	G-08	HYDRAULIC PROFILE
<b>PLAN AND PROFILE</b>		
09	PP-01	KEY PLAN SOUTH
10	PP-02	PLAN AND PROFILE STA: 280+00 TO 284+00
11	PP-03	PLAN AND PROFILE STA: 284+00 TO 288+00
12	PP-04	PLAN AND PROFILE STA: 288+00 TO 293+00
13	PP-05	PLAN AND PROFILE STA: 293+00 TO 298+00
14	PP-06	PLAN AND PROFILE STA: 298+00 TO 303+00
15	PP-07	PLAN AND PROFILE STA: 303+00 TO 308+00
16	PP-08	PLAN AND PROFILE STA: 308+00 TO 313+00
16A	PP-09	PLAN AND PROFILE STA: 313+00 TO 315+56
16B	PP-10	DAY ROAD TRENCHLESS CROSSING PLAN AND PROFILE STA: 309+50 TO 314+50
<b>PIPELINE DETAILS</b>		
17	D-01	PIPELINE DETAILS I
18	D-02	PIPELINE DETAILS II
18A	D-03	PIPELINE DETAILS III
18B	D-04	PIPELINE DETAILS IV
<b>SPECIAL PLANS</b>		
19	SP-01	BLOW OFF AND AIR VALVE ASSEMBLY PLANS AND SECTION
19A	SP-02	BLOW OFF AND AIR VALVE ASSEMBLY PLANS AND SECTION II
<b>CATHODIC PROTECTION</b>		
20	CP-01	CATHODIC PROTECTION GENERAL NOTES, ABBREVIATIONS, AND SCHEDULE
21	CP-02	CATHODIC PROTECTION DETAILS I
22	CP-03	CATHODIC PROTECTION DETAILS II
23	CP-04	CATHODIC PROTECTION DETAILS III
24	CP-05	CATHODIC PROTECTION DETAILS IV
25	CP-06	CATHODIC PROTECTION DETAILS V

SHEET INDEX		
SHEET NUMBER	DRAWING NUMBER	DESCRIPTION
<b>STANDARD DETAILS</b>		
26	SD-01	PIPE STANDARD DETAILS I
27	SD-02	PIPE STANDARD DETAILS II
28	SD-03	PIPE STANDARD DETAILS III
29	SD-04	PIPE STANDARD DETAILS IV
30	SD-05	PIPE STANDARD DETAILS V
31	SD-06	PIPE STANDARD DETAILS VI
32	SD-07	PIPE STANDARD DETAILS VII
33	SD-08	PIPE STANDARD DETAILS VIII
34	SD-09	PIPE STANDARD DETAILS IX
35	SD-10	PIPE STANDARD DETAILS X
36	SD-11	APPURTENANCE STANDARD DETAILS I
37	SD-12	APPURTENANCE STANDARD DETAILS II
38	SD-13	APPURTENANCE STANDARD DETAILS III
39	SD-14	APPURTENANCE STANDARD DETAILS IV
40	SD-15	APPURTENANCE STANDARD DETAILS V
<b>TRAFFIC CONTROL PLANS (TCP)</b>		
41	TC-01	TRAFFIC CONTROL PLANS VICINITY MAP AND HAUL ROUTE
42	TC-02	TRAFFIC CONTROL PLANS LEGEND AND GENERAL NOTES
43	TC-03	SW DAY ROAD TCP STAGE 1
<b>EROSION CONTROL AND FENCING</b>		
44	EC-01	EROSION AND SEDIMENT CONTROL PLAN
45	EC-02	CITY OF WILSONVILLE STANDARD EROSION CONTROL DETAILS

DISCIPLINE DESIGNATOR	
DISCIPLINE	DESIGNATOR
GENERAL	G
CIVIL	C
PLAN AND PROFILES	PP
PIPELINE DETAILS	D
CATHODIC PROTECTION	CP
GRADING	GR
SPECIAL PLANS	SP
RESTORATION AND LANDSCAPING	RL
EROSION CONTROL AND FENCING	EC
TRAFFIC CONTROL PLANS (TCP)	TC
STANDARD DETAILS	SD



**KNOW WHAT'S BELOW.  
CALL BEFORE YOU DIG. 811**  
"LOOK UP AND LIVE"

DSGN	D. Johnston				
DR	S. Kuhns				
CHK	A. Stevens	4	03/20		
APVD	E. Hadler	0	07/19		
		NO.	DATE	REVISION	BY

**VERIFY SCALE**  
BAR IS ONE INCH ON ORIGINAL DRAWING.  
IF NOT ONE INCH ON THIS SHEET, ADJUST SCALES ACCORDINGLY.



PLM\_1.2  
Water Transmission Line  
Schedule B

GENERAL  
INDEX OF DRAWINGS

SHEET	02
DWG	G-02
DATE	03/06/2020
PROJ	PROJ

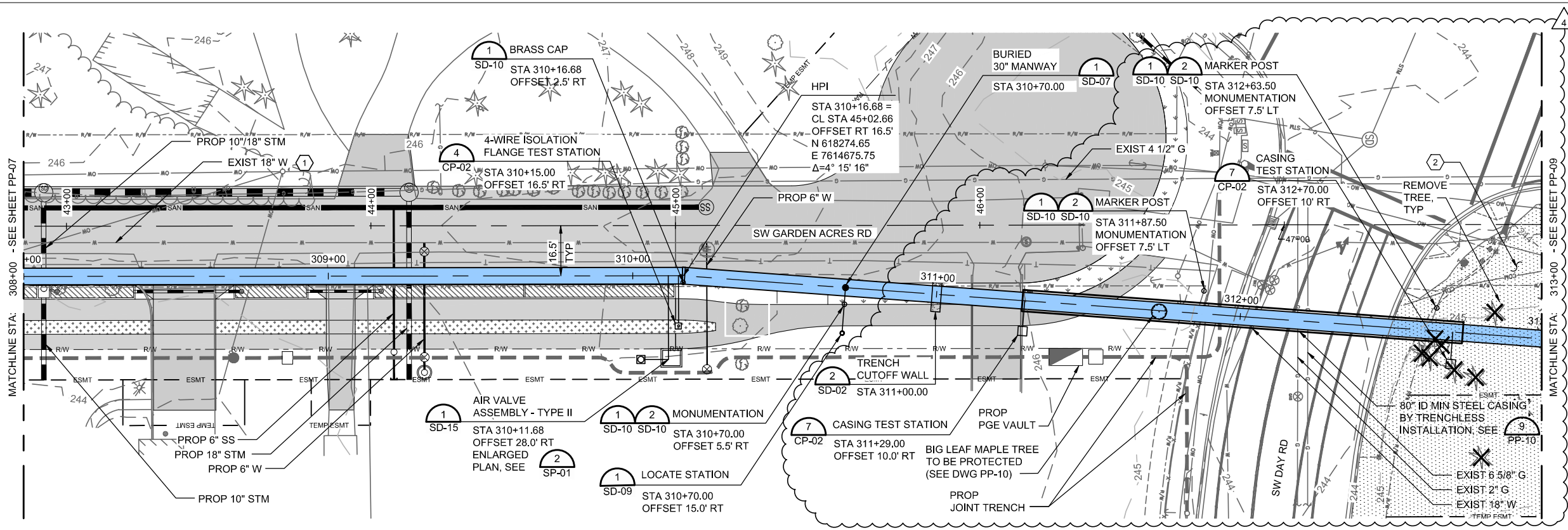

7 PLAN

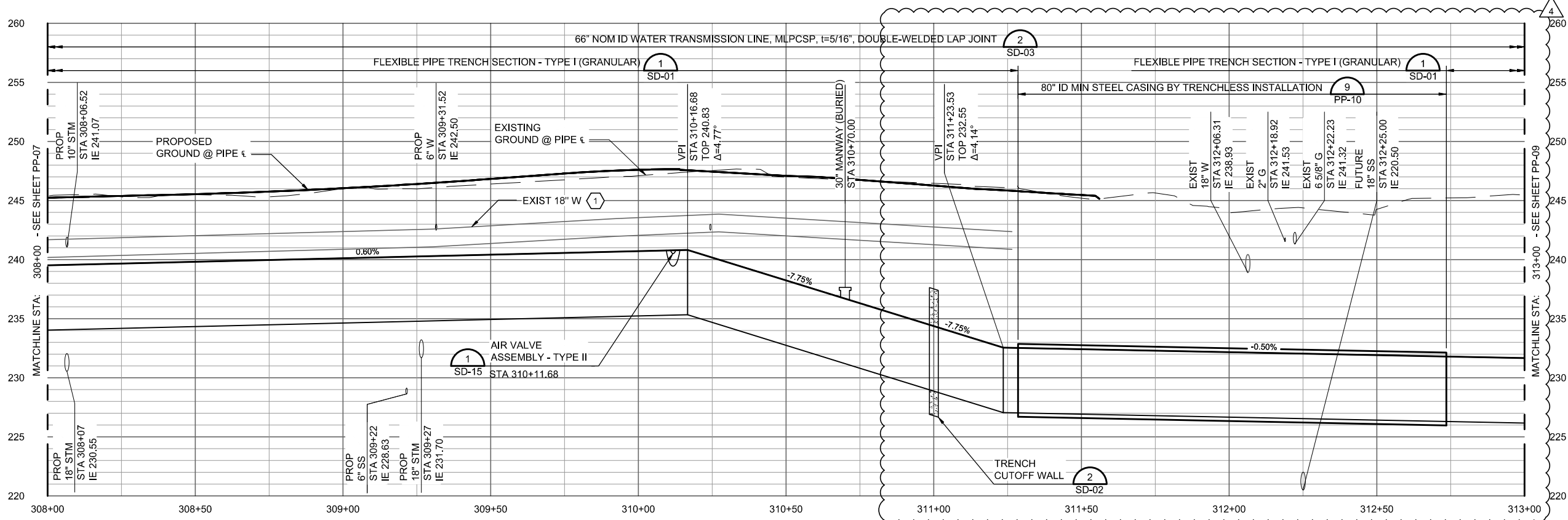

7 PROFILE

NOTES:

- REFER TO ROADWAY DESIGN PLANS (SCHEDULE A) FOR SURVEY INFORMATION AND PROJECT CONTROLS.
- REFER TO SCHEDULE A DRAWINGS FOR INFORMATION PERTAINING TO THE ROADWAY DESIGN AND ASSOCIATED DRAINAGE, UTILITIES, SIGNAGE, UTILITY RELOCATIONS, LIGHTING, STRIPING, LANDSCAPING, IRRIGATION, EROSION AND SEDIMENTATION CONTROL, AND MAINTENANCE OF TRAFFIC.
- PIPELINE CURVE RADII SHOWN ON THE PLANS REQUIRES THE USE OF JOINT DEFLECTION THROUGH PULLED JOINTS, AND/OR BEVELED JOINTS. SEE THE SPECIFICATIONS FOR JOINT DESIGN REQUIREMENTS.
- CONTRACTOR SHALL FIELD VERIFY THE LOCATION OF THE EXISTING WATER SERVICES (NOT SHOWN). CONTRACTOR SHALL PROTECT THE EXISTING WATER SERVICES AND THE PROPOSED JOINT TRENCH IN ORDER TO MAINTAIN SERVICES THROUGHOUT CONSTRUCTION.

KEY NOTES:

- CONTRACTOR SHALL PROTECT THE EXISTING 18\"/>
- PLANT PERMANENT SEEDING - 0.14 ACRES.

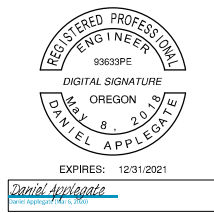
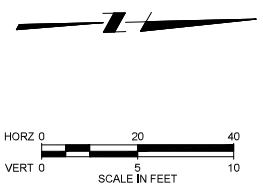

**KNOW WHAT'S BELOW. CALL BEFORE YOU DIG. 811**  
"LOOK UP AND LIVE"

DSGN	D. Applegate	NO.	DATE	REVISION	BY	APVD
DR	S. Kuhns	4	03/20	DESIGN CLARIFICATION DC-04		
CHK	A. Stevens	1	09/19	DESIGN CLARIFICATION 01		
APVD	E. Hadler	0	07/19	CONFORMED CONSTRUCTION DRAWINGS		

VERIFY SCALE  
BAR IS ONE INCH ON ORIGINAL DRAWING.  
IF NOT ONE INCH ON THIS SHEET, ADJUST SCALES ACCORDINGLY.



**Willamette Water Supply**  
Our Reliable Water

PLM\_1.2  
Water Transmission Line  
Schedule B

CIVIL  
PLAN AND PROFILE  
STA: 308+00 TO 313+00

SHEET	16
DWG	PP-08
DATE	03/06/2020
PROJ	PROJ

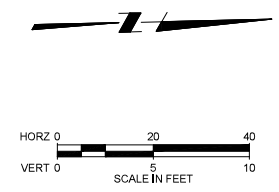
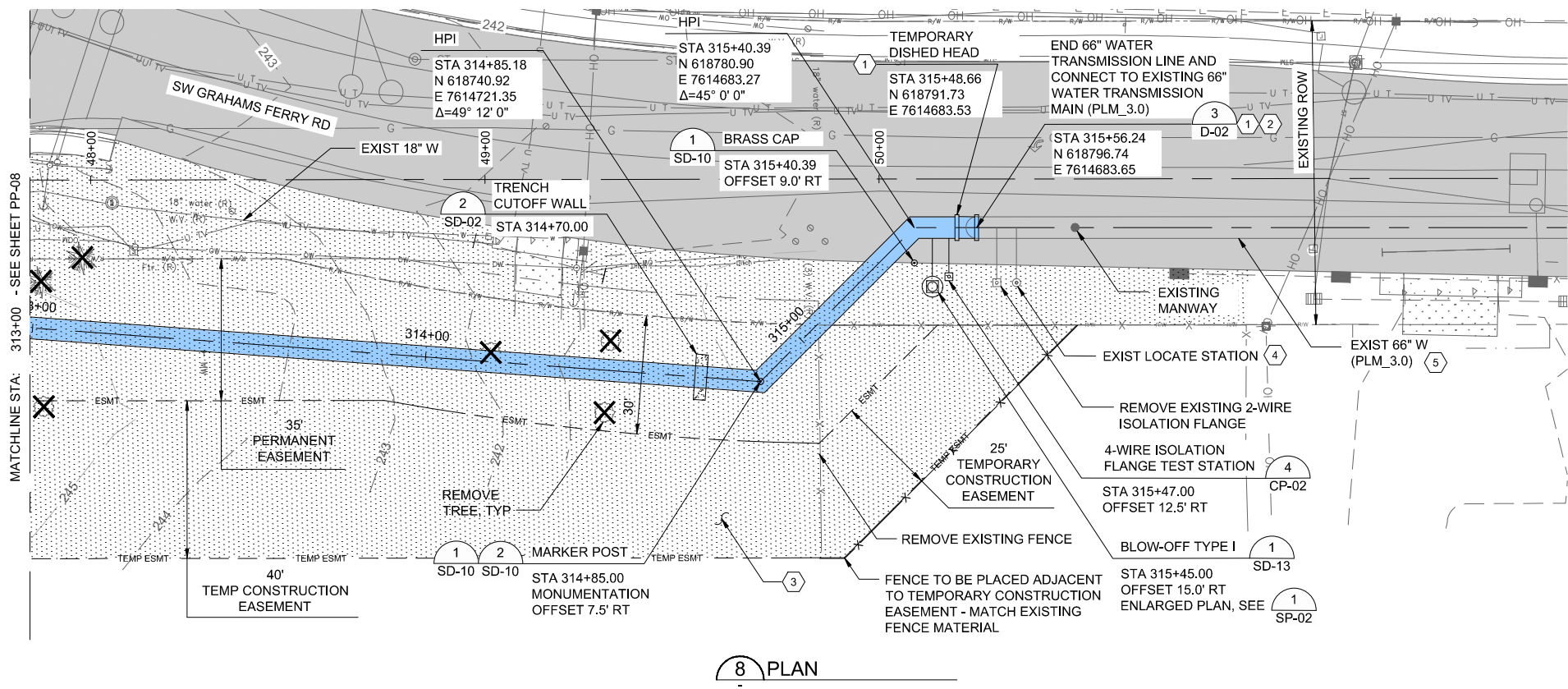

- NOTES:**
- REFER TO ROADWAY DESIGN PLANS (SCHEDULE A) FOR SURVEY INFORMATION AND PROJECT CONTROLS.
  - REFER TO SCHEDULE A DRAWINGS FOR INFORMATION PERTAINING TO THE ROADWAY DESIGN AND ASSOCIATED DRAINAGE, UTILITIES, SIGNAGE, UTILITY RELOCATIONS, LIGHTING, STRIPING, LANDSCAPING, IRRIGATION, EROSION AND SEDIMENTATION CONTROL, AND MAINTENANCE OF TRAFFIC.
  - PIPELINE CURVE RADII SHOWN ON THE PLANS REQUIRES THE USE OF JOINT DEFLECTION THROUGH PULLED JOINTS, AND/OR BEVELED JOINTS. SEE THE SPECIFICATIONS FOR JOINT DESIGN REQUIREMENTS.
  - CONTRACTOR SHALL FIELD VERIFY THE LOCATION OF THE EXISTING WATER SERVICES (NOT SHOWN). CONTRACTOR SHALL PROTECT THE EXISTING WATER SERVICES AND THE PROPOSED JOINT TRENCH IN ORDER TO MAINTAIN SERVICES THROUGHOUT CONSTRUCTION.

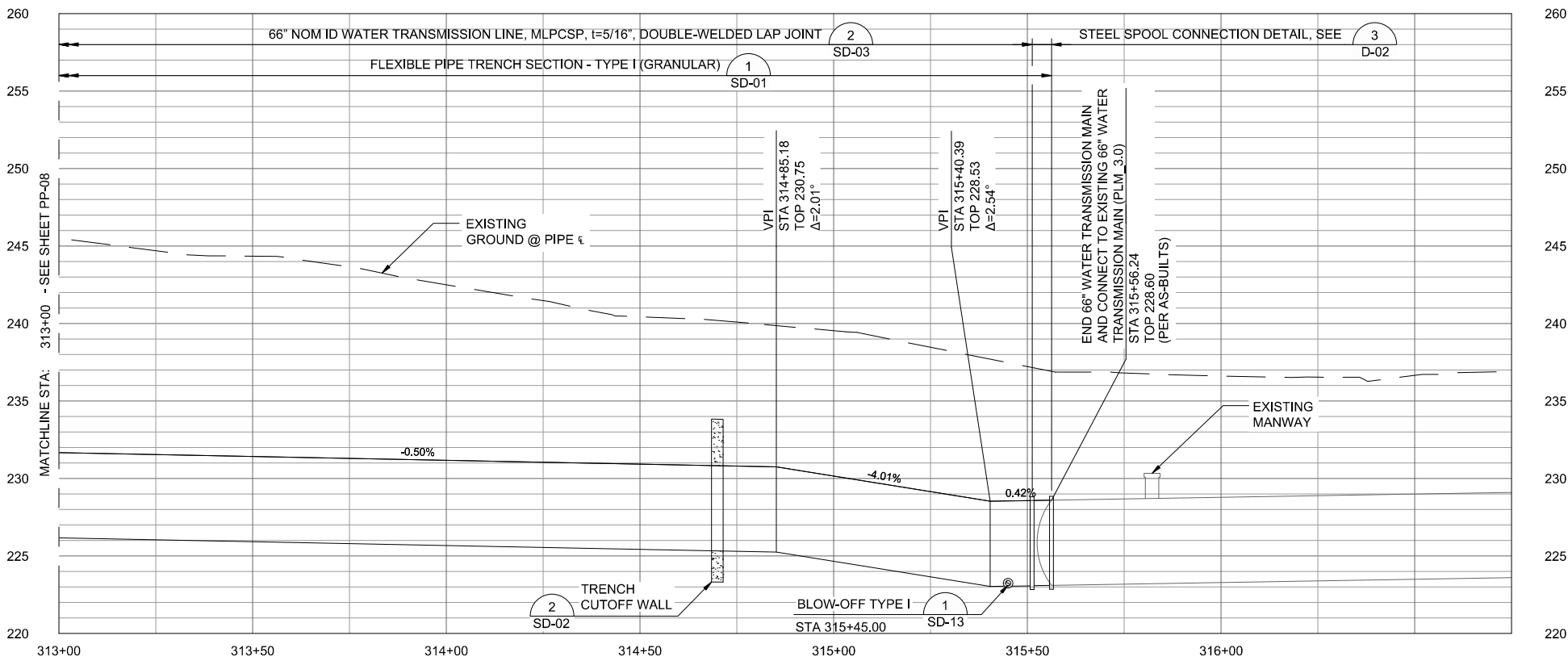

- KEY NOTES:**
- INSTALL TEMPORARY DISHED HEAD FOR HYDROSTATIC TESTING OF NEW MAIN. AFTER SUCCESSFUL COMPLETION AND ACCEPTANCE BY THE OWNER, CONTRACTOR SHALL REMOVE NEW AND EXISTING DISHED HEAD SECTION AND ALL COMPONENTS ASSOCIATED WITH 6" BLOW-OFF VALVE AND TEMPORARY MANHOLE. VALVE STEM EXTENSION SHALL BE SALVAGED.
  - PAVEMENT RESTORATION TO MATCH EXISTING THICKNESS AND MATERIAL OR MIN. 8" ASPHALT OVER 13" AGGREGATE BASE COURSE, WHICHEVER IS GREATER. RESTORE PAVEMENT, CURB, AND GUTTER DISTURBED BY CONSTRUCTION IN ACCORDANCE WITH JURISDICTIONAL REQUIREMENTS.
  - PLANT PERMANENT SEEDING - 0.49 ACRES
  - PROTECT EXISTING LOCATE STATION AND LOCATE WIRES. CONNECT NEW LOCATING WIRE TO EXISTING LOCATE STATION.
  - THE EXISTING PLM 3.0 66" WATER MAIN WAS DRAINED IN 2019, BUT MAY STILL CONTAIN A SMALL VOLUME OF HIGH PH WATER. PRIOR TO CONNECTION, PROVIDE CONTRACTOR SAFETY, WATER TREATMENT, AND WATER DISCHARGE PLAN FOR REVIEW. PROVIDE TESTING, TREATMENT, AND DISCHARGE OF WATER IN ACCORDANCE WITH WSP AND PERMITTING REQUIREMENTS. EXISTING PLM 3.0 66" WATER MAIN PARAMETERS:  
OUTSIDE DIAMETER = 67.875"  
STEEL CYLINDER WALL THICKNESS = 0.375"  
CEMENT MORTAR LINED  
POLYURETHANE COATED

**KNOW WHAT'S BELOW. CALL BEFORE YOU DIG. 811**  
"LOOK UP AND LIVE"

DSGN	D. Applegate				
DR	S. Kuhns				
CHK	A. Stevens	4	03/20		
APVD	E. Hadler	0	07/19		
		NO.	DATE	REVISION	BY

VERIFY SCALE  
BAR IS ONE INCH ON ORIGINAL DRAWING.  
IF NOT ONE INCH ON THIS SHEET, ADJUST SCALES ACCORDINGLY.



PLM\_1.2  
Water Transmission Line  
Schedule B

CIVIL  
PLAN AND PROFILE  
STA: 313+00 TO 315+56

SHEET	16A
DWG	PP-09
DATE	03/06/2020
PROJ	PROJ

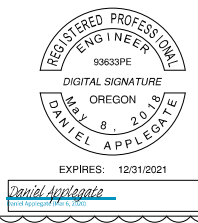



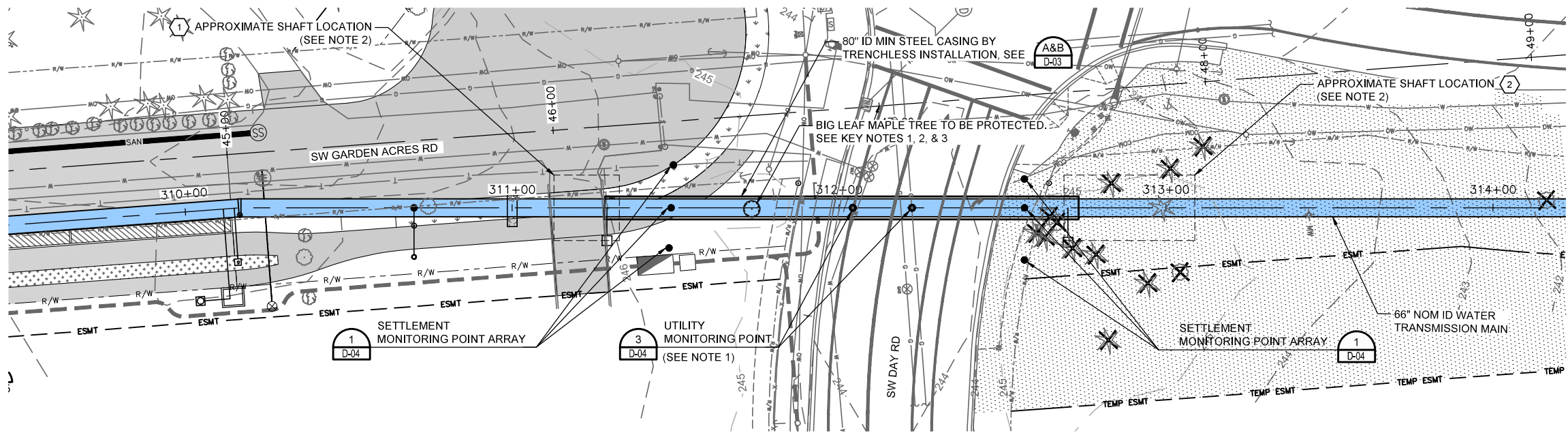

9 PLAN

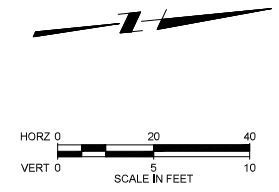

- LEGEND:**
- SETTLEMENT MONITORING POINT
  - UTILITY MONITORING POINT

- NOTES:**
1. CONTACT AND COORDINATE WITH UTILITY OWNER BEFORE CONSTRUCTING UTILITY MONITORING POINTS.
  2. SHAFT LOCATION AND SIZE IS APPROXIMATE AND IS SHOWN FOR REFERENCE PURPOSES ONLY.

- KEY NOTES:**
1. LOCATE SHAFT BASED ON AVOIDANCE OF TREE CANOPY WHICH EXTENDS 38-FOET SOUTH OF BIGLEAF MAPLE TREE TRUNK PER PLM\_1.2-MAPLE TREE EVALUATION.
  2. LOCATE SHAFT BASED ON MAINTAINING A MINIMUM OF 2-FOET FROM EDGE OF SHAFT TO SW DAY ROAD ROW LINE AND BURIED COMMUNICATION LINES.
  3. CONTACT AND COORDINATE WITH ARBORIST A MINIMUM OF 1 WEEK PRIOR TO CONSTRUCTION TO SUPERVISE TREE PROTECTION PRIOR TO AND DURING CONSTRUCTION. SEE CITY OF WILSONVILLE PUBLIC WORKS STANDARD DETAIL RD-1230 TREE PROTECTION FENCING ON SHEET EC-02.

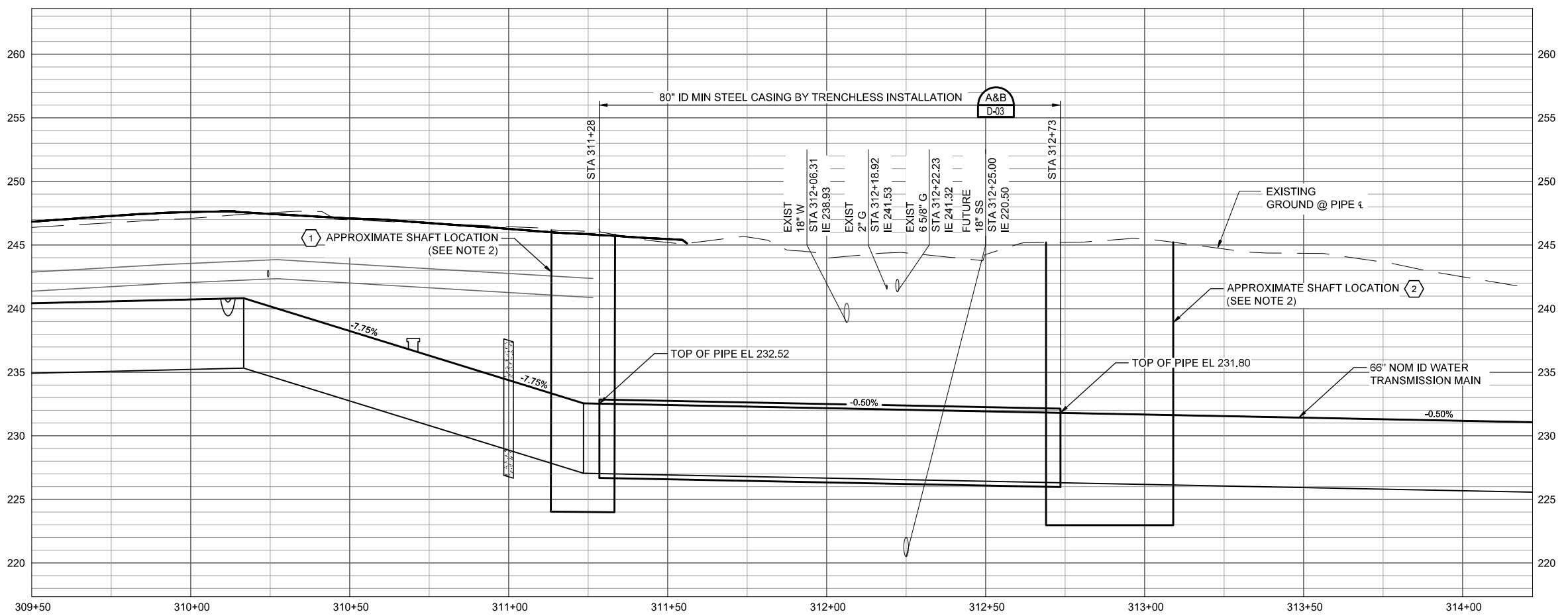

9 PROFILE



**KNOW WHAT'S BELOW. CALL BEFORE YOU DIG. 811**  
"LOOK UP AND LIVE"

DSGN	L. Erickson				
DR	R. Carpenter				
CHK	L. Erickson	4	03/20	DESIGN CLARIFICATION DC-04	
APVD	Y. Lang	NO.	DATE	REVISION	BY

**VERIFY SCALE**  
BAR IS ONE INCH ON ORIGINAL DRAWING.  
IF NOT ONE INCH ON THIS SHEET, ADJUST SCALES ACCORDINGLY.



**Willamette Water Supply**  
Our Reliable Water

PLM\_1.2  
Water Transmission Line  
Schedule B

CIVIL  
**DAY ROAD TRENCHLESS CROSSING**  
PLAN AND PROFILE  
STA: 309+50 TO 314+50

SHEET	16B
DWG	PP-10
DATE	03/06/2020
PROJ	PROJ

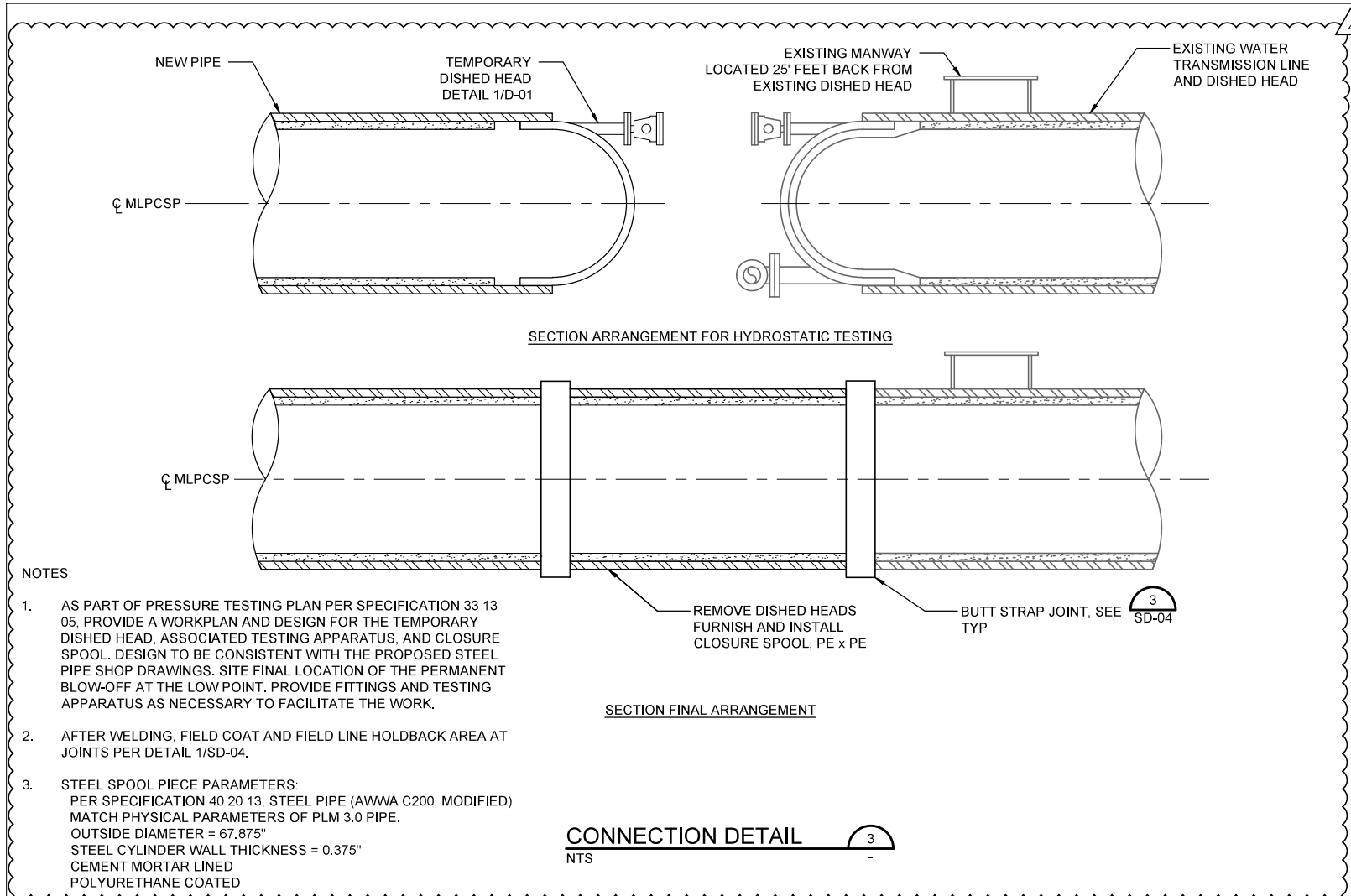

- NOTES:**
- AS PART OF PRESSURE TESTING PLAN PER SPECIFICATION 33 13 05, PROVIDE A WORKPLAN AND DESIGN FOR THE TEMPORARY DISHED HEAD, ASSOCIATED TESTING APPARATUS, AND CLOSURE SPOOL. DESIGN TO BE CONSISTENT WITH THE PROPOSED STEEL PIPE SHOP DRAWINGS. SITE FINAL LOCATION OF THE PERMANENT BLOW-OFF AT THE LOW POINT. PROVIDE FITTINGS AND TESTING APPARATUS AS NECESSARY TO FACILITATE THE WORK.
  - AFTER WELDING, FIELD COAT AND FIELD LINE HOLDBACK AREA AT JOINTS PER DETAIL 1/SD-04.
  - STEEL SPOOL PIECE PARAMETERS:  
PER SPECIFICATION 40 20 13, STEEL PIPE (AWWA C200, MODIFIED)  
MATCH PHYSICAL PARAMETERS OF PLM 3.0 PIPE.  
OUTSIDE DIAMETER = 67.875"  
STEEL CYLINDER WALL THICKNESS = 0.375"  
CEMENT MORTAR LINED  
POLYURETHANE COATED

**CONNECTION DETAIL** 3  
NTS

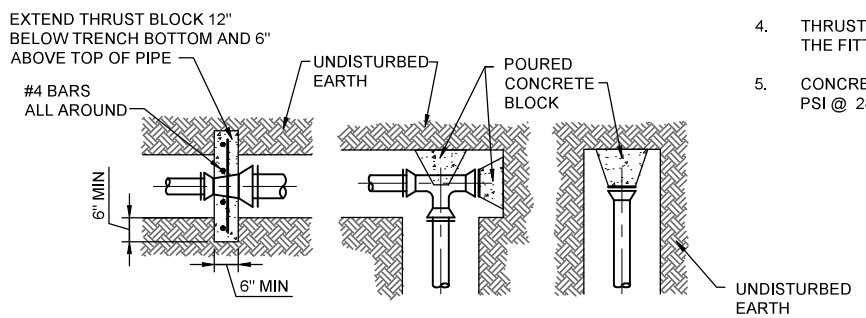
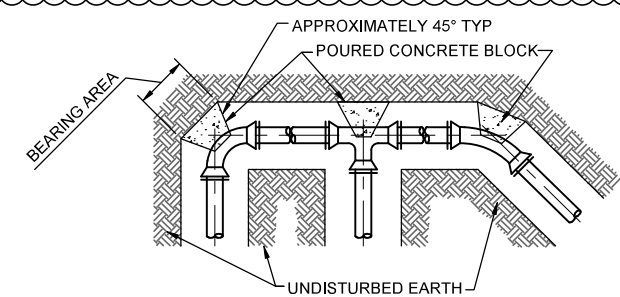

**THRUST BLOCK** 1  
NTS

- NOTES:**
- WAX TAPE WRAP FITTINGS (LENGTH + 6" MIN OVERLAP). CONSTRUCT BLOCK SUCH THAT CONCRETE DOES NOT INTERFERE WITH THE ADJACENT PIPE JOINT.
  - THE HEIGHT (h) OF THE BLOCK SHALL BE EQUAL TO OR LESS THAN 1/2 THE TOTAL DEPTH FROM FINISHED GRADE TO THE BOTTOM THE BLOCK BUT NOT LESS THAN THE PIPE DIAMETER.
  - THE HORIZONTAL DIMENSION OF THE BEARING AREA SHALL BE BETWEEN 1 AND 2 TIMES THE VERTICAL DIMENSION.
  - THRUST BLOCK ORIENTATION SHALL BE SUCH THAT THE CENTER OF THE FITTING CORRESPONDS WITH THE CENTER OF THE THRUST BLOCK.
  - CONCRETE SHALL HAVE A MINIMUM COMPRESSIVE STRENGTH OF 4000 PSI @ 28 DAYS.

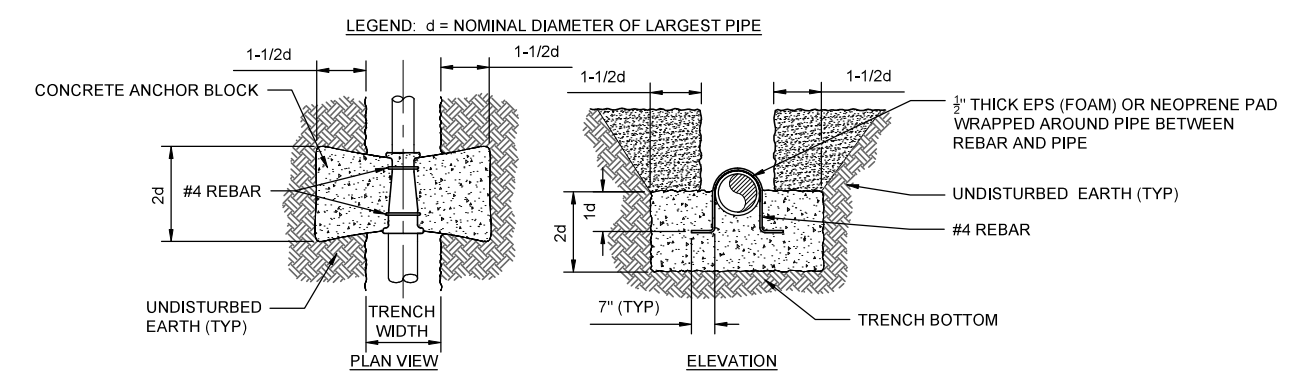

**IN-LINE REDUCERS**

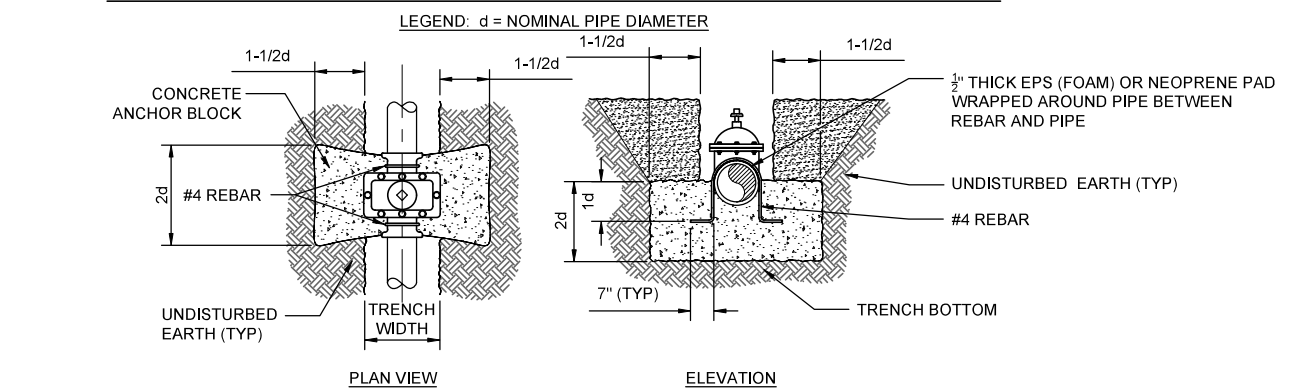

**IN-LINE VALVES**

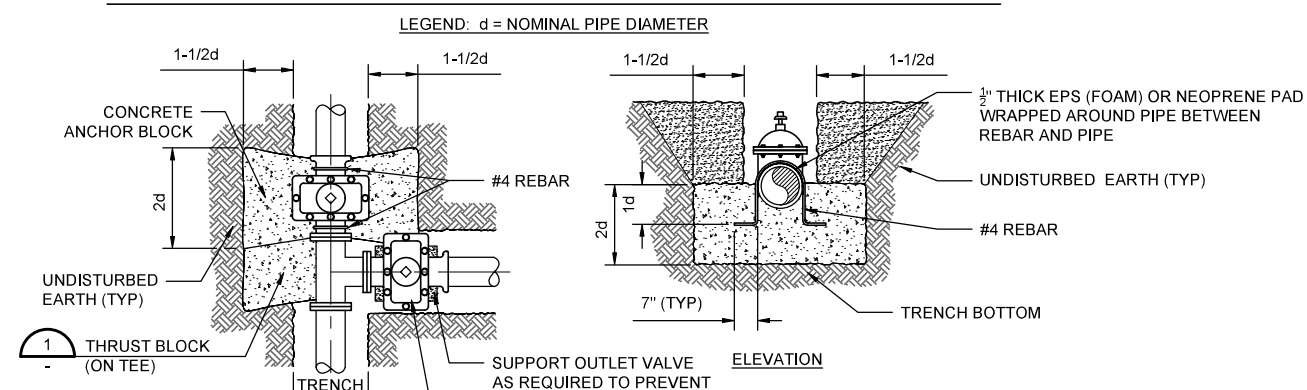

**TEE VALVES**

- NOTES:**
- ALL CONCRETE SHALL BE MIN 4000 PSI @ 28 DAYS COMPRESSIVE STRENGTH.
  - EXPOSED REBAR TO BE COATED IN ACCORDANCE WITH THE SPECIFICATIONS. WRAP ALL VALVES WITH WAX TAPE WRAPPING (LENGTH + 6" MIN OVERLAP).
  - WHEN PIPE IS INSTALLED BETWEEN TEE AND OUTLET VALVE AN ADDITIONAL CONCRETE ANCHOR BLOCK WILL BE REQUIRED ON THE OUTLET VALVE.

**ANCHOR BLOCK FOR REDUCERS, GATE VALVES, AND BUTTERFLY VALVES** 2  
NTS

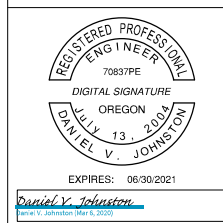

DSGN	D. Johnston					
DR	S. Kuhns					
CHK	A. Stevens	4	03/20			
APVD	E. Hadler	0	07/19			
		NO.	DATE	REVISION	BY	APVD

VERIFY SCALE  
BAR IS ONE INCH ON ORIGINAL DRAWING.  
IF NOT ONE INCH ON THIS SHEET, ADJUST SCALES ACCORDINGLY.



PLM\_1.2  
Water Transmission Line  
Schedule B

PIPELINE DETAILS  
PIPELINE DETAILS II

SHEET	18
DWG	D-02
DATE	03/06/2020
PROJ	PROJ

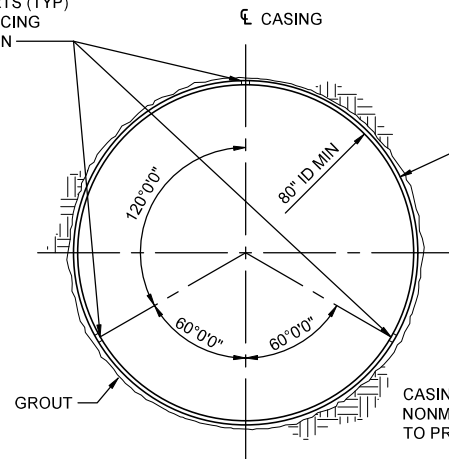

STEEL CASING SECTION  
SCALE: NTS

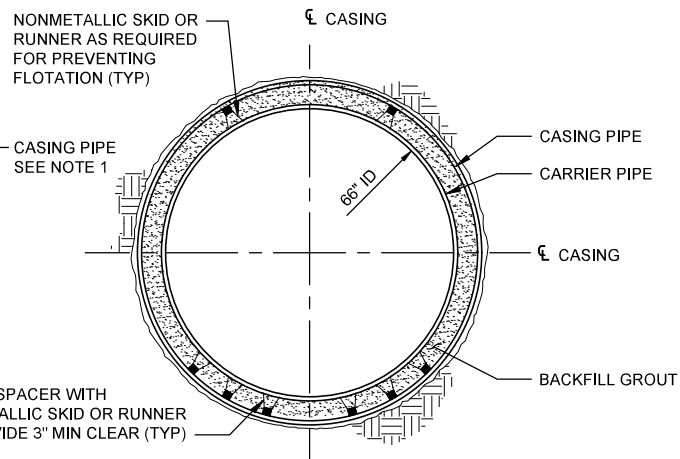

STEEL CASING AND CARRIER PIPE SECTION  
SCALE: NTS

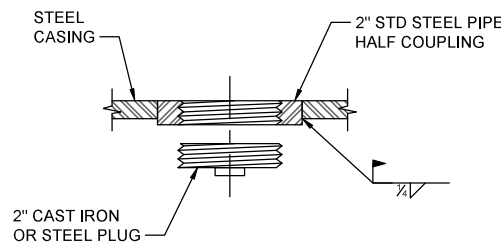

STEEL CASING GROUT PORT DETAIL  
SCALE: NTS

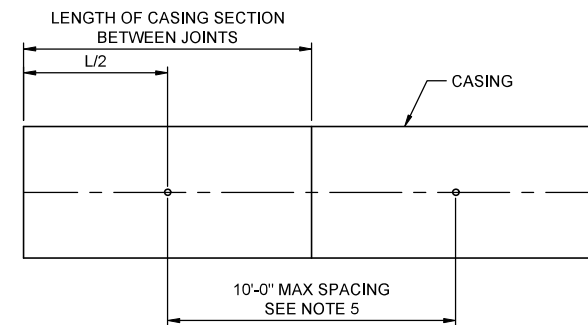

GROUT PORT SPACING DETAIL  
SCALE: NTS

NOTES:

1. STEEL CASING SHALL HAVE A MINIMUM WALL THICKNESS OF 1/2".
2. SEE SPECIFICATION 33 05 23.20 FOR STEEL CASING REQUIREMENTS.
3. SEE SPECIFICATIONS 33 05 23.16 FOR STEEL CASING INSTALLATION USING TRENCHLESS CONSTRUCTION METHODS.
4. MINIMUM ANNULAR CLEARANCE BETWEEN CASING AND CARRIER PIPE SHALL BE 3".
5. PROVIDE ONE SET OF 3 GROUT PORTS PER CASING SECTION OR 10' ON CENTER WHICHEVER RESULTS IN A CLOSER SPACING.
6. CONTACT GROUT ANNULAR SPACE OUTSIDE CASING PER REQUIREMENTS IN SPECIFICATION 33 05 23.16.

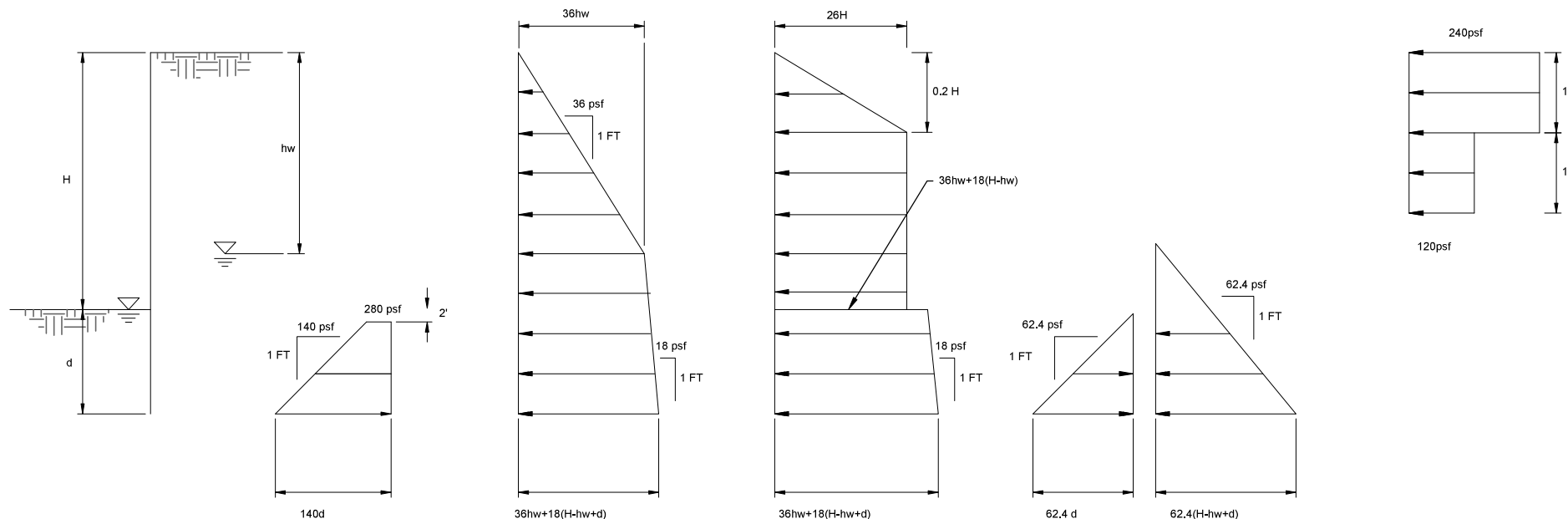

NOTES:

1. THE ACTIVE AND APPARENT EARTH PRESSURES ARE THE MINIMUM TO BE USED FOR DESIGN OF THE TRENCHLESS CROSSING ENTRY AND EXIT SHAFT EXCAVATION SUPPORT SYSTEMS. THE LOADS DO NOT INCLUDE ANY FACTOR OF SAFETY THAT MUST BE APPLIED IN THE EXCAVATION SUPPORT SYSTEM DESIGN. CONTRACTOR IS RESPONSIBLE FOR EVALUATING ACTUAL LOADS, BUT IN NO CASE SHALL BE LESS THEN THAT SHOWN.
2. DEPENDING ON SUPPORT OF EXCAVATION DESIGN, USE EITHER ACTIVE PRESSURE OR APPARENT PRESSURE. USING BOTH SIMULTANEOUSLY IS NOT REQUIRED.
3. THE TEMPORARY SURCHARGE LOAD SHOWN IS BASED ON A 20' WIDE STRIP LOAD OF 600 PSF FROM THE EDGE OF SHORING. IF CONTRACTOR SURCHARGE IS HIGHER, LOADING MUST BE INCREASED.

LEGEND:

- H HEIGHT OF EXCAVATION (TEMPORARY) IN FEET
- hw DISTANCE FROM GROUND SURFACE TO WATER LEVEL
- d DEPTH OF EMBEDMENT

LATERAL EARTH PRESSURES FOR TEMPORARY EXCAVATION SHORING  
SCALE: NOT TO SCALE



KNOW WHAT'S BELOW.  
CALL BEFORE YOU DIG. 811  
"LOOK UP AND LIVE"

DSGN	L. Erickson				
DR	R. Carpenter				
CHK	L. Erickson	4	03/20		
APVD	Y. Lang	3	12/19		
		NO.	DATE	REVISION	BY

VERIFY SCALE  
BAR IS ONE INCH ON ORIGINAL DRAWING.  
IF NOT ONE INCH ON THIS SHEET, ADJUST SCALES ACCORDINGLY.



Willamette Water Supply  
Our Reliable Water

PLM\_1.2  
Water Transmission Line  
Schedule B

CIVIL  
PIPELINE DETAILS III

SHEET	18A
DWG	D-03
DATE	03/06/2020
PROJ	PROJ

**NOTES:**

1. INSTRUMENTATION INSTALLATION METHODS, EQUIPMENT, MATERIALS, TIMING, TOLERANCES AND INSTRUMENTATION MONITORING, AND THE REPORTING RESULTS SHALL COMPLY WITH THE REQUIREMENTS OF SPECIFICATION 31 09 00.
2. SPACING OF SETTLEMENT MONITORING POINTS IS SHOWN ON DWG PP-10. ADJUST INSTRUMENT AND MONITORING LOCATIONS AS APPROVED OR DIRECTED BY THE OWNER'S REPRESENTATIVE TO AVOID EXISTING UTILITIES AND MINIMIZE CONFLICTS WITH CONSTRUCTION OPERATIONS.
3. PRIOR TO CONSTRUCTION, OBTAIN PERMITS AND COMPLY WITH REQUIREMENTS OF THE AGENCIES, OWNERS, UTILITIES, AND OTHER ENTITIES WITH JURISDICTION OVER ACCESS AND INSTALLATION OF THE INSTRUMENTATION.

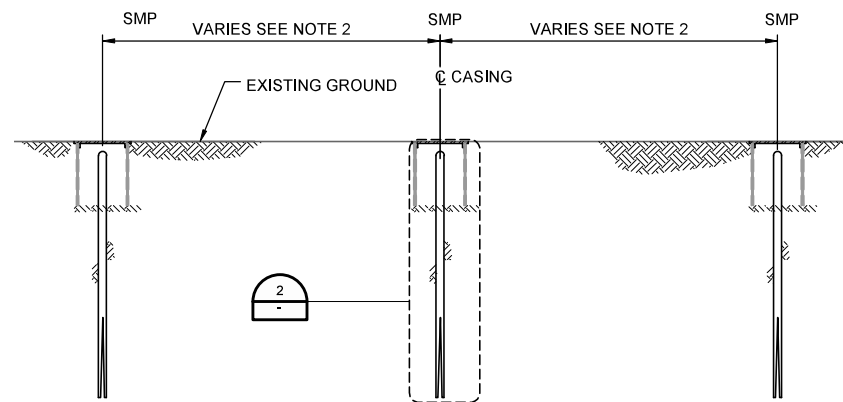

SETTLEMENT MONITORING POINT ARRAY DETAIL  
SCALE: NTS

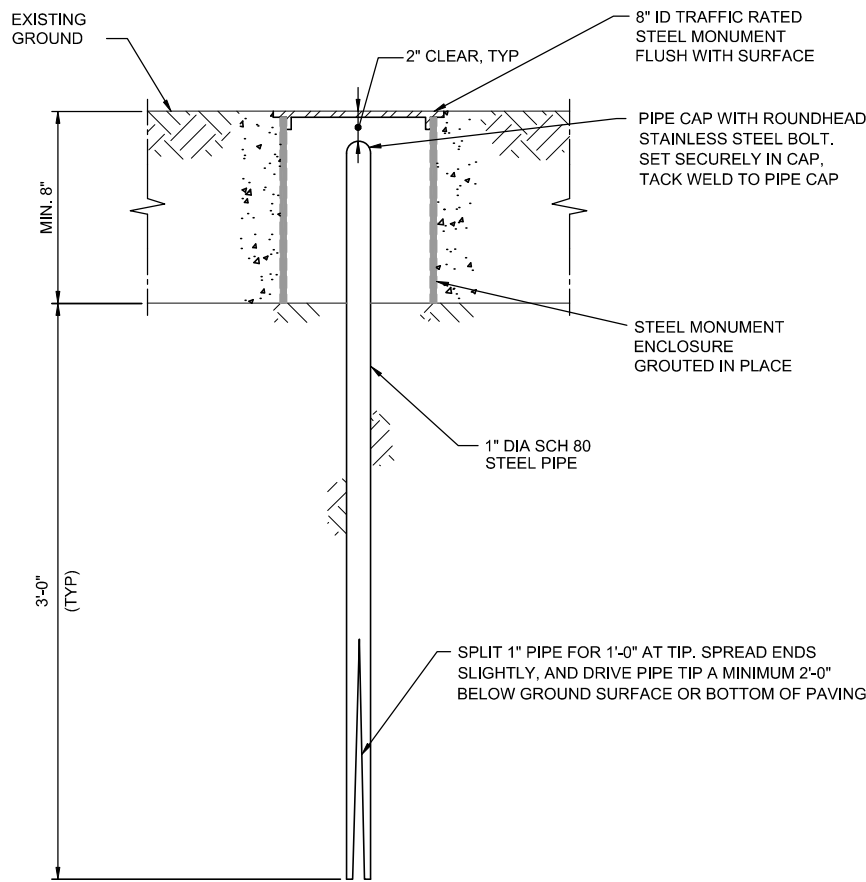

SETTLEMENT MONITORING POINT (SMP) WITH SURFACE MONUMENT  
SCALE: NTS

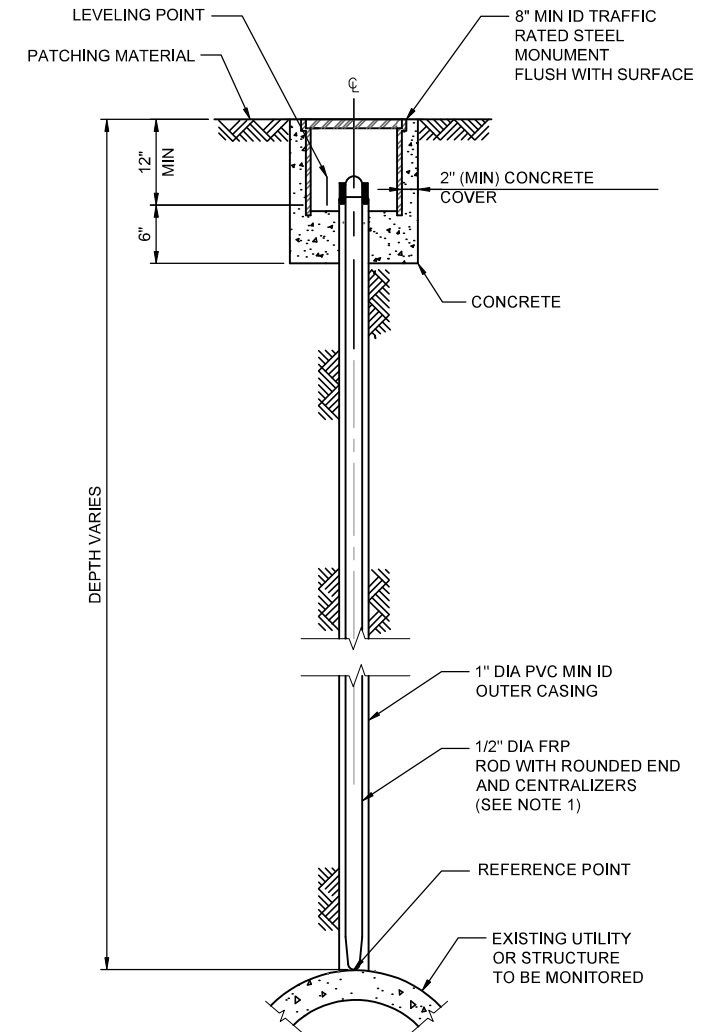

**NOTES:**

1. ROD WITH STABILIZERS NOT REQUIRED FOR GAS LINE UTILITY MONITORING POINT.

UTILITY MONITORING POINT  
SCALE: NTS



**KNOW WHAT'S BELOW. CALL BEFORE YOU DIG. 811**  
"LOOK UP AND LIVE"

DSGN	L. Erickson						
DR	R. Carpenter						
CHK	L. Erickson	4	03/20	DESIGN CHANGE DC-04			
APVD	Y. Lang	NO.	DATE	REVISION	BY	APVD	

VERIFY SCALE  
BAR IS ONE INCH ON ORIGINAL DRAWING.  
IF NOT ONE INCH ON THIS SHEET, ADJUST SCALES ACCORDINGLY.



Willamette Water Supply  
Our Reliable Water

PLM\_1.2  
Water Transmission Line  
Schedule B

CIVIL  
PIPELINE DETAILS IV

SHEET	18B
DWG	D-04
DATE	03/06/2020
PROJ	PROJ

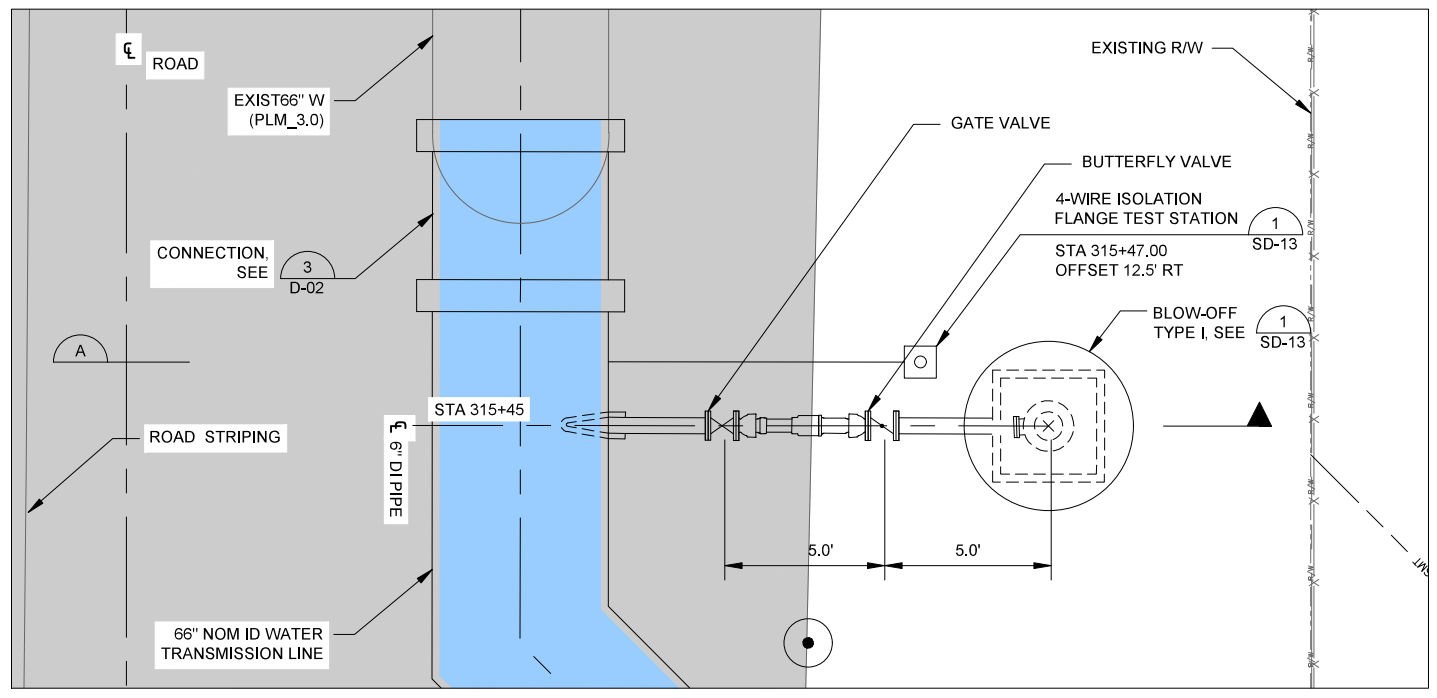

1 PLAN - STA 315+45.00  
PP-09

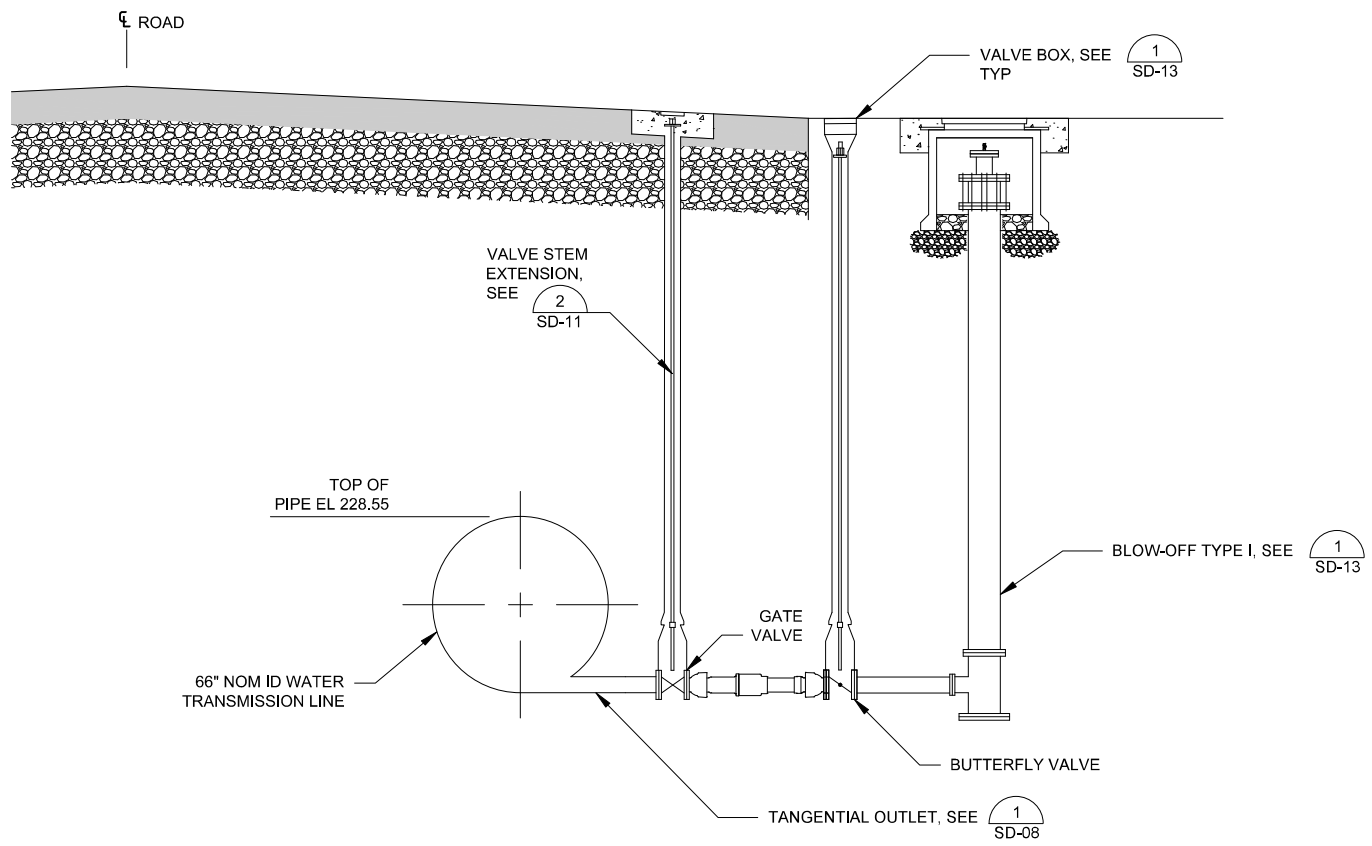
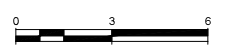

A SECTION  
SCALE: 1" = 3'-0"

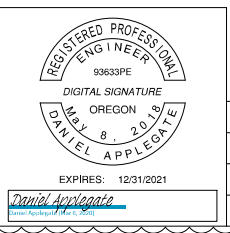

DSGN	D. Applegate				
DR	S. Kuhns				
CHK	A. Stevens	4	03/20		
APVD	E. Hadler	0	07/19		
		NO.	DATE	REVISION	BY

VERIFY SCALE  
BAR IS ONE INCH ON ORIGINAL DRAWING.  
IF NOT ONE INCH ON THIS SHEET, ADJUST SCALES ACCORDINGLY.



Willamette Water Supply  
Our Reliable Water

PLM\_1.2  
Water Transmission Line  
Schedule B

CIVIL  
BLOW OFF AND AIR VALVE ASSEMBLY  
PLANS AND SECTION II

SHEET	19A
DWG	SP-02
DATE	03/06/2020
PROJ	PROJ

**GENERAL NOTES**

1. ALL MATERIALS AND INSTALLATION METHODS SHALL BE IN ACCORDANCE WITH THESE DRAWINGS AND TECHNICAL SPECIFICATIONS.
2. UNLESS OTHERWISE NOTED DRAWINGS ARE NOT SHOWN TO SCALE.
3. CORROSION TEST STATIONS:
  - A. INSTALL TEST STATION BOXES AS SHOWN IN THE PLANS AND PERPENDICULAR TO THE TEST WIRE CONNECTION POINT. TEST STATION LOCATIONS MAY BE MOVED ±5' FROM THE STATIONS SHOWN TO AVOID DRIVEWAYS OR INTERFERENCE WITH OTHER STRUCTURES. COORDINATE INSTALLATION OF TEST STATION CONDUIT WITH POSTS AND OTHER FIXTURES TO AVOID DAMAGE TO CONDUIT. INSTALL TEST STATION BOXES A MINIMUM OF 4' FROM EOP OR BOC.
  - B. PROVIDE 24" SLACK WIRE AT WELD TO PIPE AND COILED IN TEST BOX.
  - C. INSTALL REINFORCED CONCRETE PAD (24" SQ. x 6" THICK) AROUND TEST BOXES IN UNPAVED AREAS. USE No. 4 REBAR. SEE  CP-02
  - D. IDENTIFY TEST LEADS WITH HEAT SHRINK SLEEVE.
  - E. WIRE SIZE, INSULATION, AND COLORS SCHEDULE
    - PROJECT PIPE LEADS = No.8 AWG STRANDED THWN BLK (FOR 2-WIRE AND UP STATION WIRES OF 4-WIRE TEST STATION)
    - PROJECT PIPE LEADS = No.8 AWG STRANDED THWN BLUE (DOWN STATION WIRES OF 4-WIRE TEST STATION)
    - CASING LEADS - No.8 AWG STRANDED THWN WHITE
    - ANODE LEAD - No.12 AWG STRANDED THWN RED
    - REFERENCE ELECTRODE - No. 14 AWG RHH-RHW YELLOW
    - COUPON WIRES - No. 12 AWG THHN-THWN GREEN
    - BOND WIRE - No.4 AWG STRANDED HMWPE
    - INSULATING JOINT - NO.8 AWG THWN BLUE (FOR UNPROTECTED) BLACK (PROTECTED)
    - FOREIGN PIPELINE - NO.8 AWG THWN PURPLE
    - COUPON WIRE - NO.12 AWG-THWN GREEN
    - REFERENCE ELECTRODE WIRE - NO.14 RHH-RHW YELLOW

**\*\*PHASE TAPING OF WIRES FOR COLOR CODING IS NOT ALLOWED.**
  - F. PLACE ALL WIRE RUNS IN SCH 80 PVC CONDUIT WITH SOLVENT WELDED JOINTS @ A MIN OF 3 FEET BELOW FINISHED GRADE. ENCASE IN RED CONCRETE WITH MINIMUM 3" CLEARANCE. CONDUIT AND WIRES NOT SHOWN IN ALL DETAILS FOR CLARITY.
4. ANODE INSTALLATION NOTES:
  - A. INSTALL ANODES ACCORDING TO THE PLANS AND SPECIFICATIONS.
  - B. INSTALL PLASTIC WARNING TAPE ALONG ENTIRE HORIZONTAL RUN OF WIRES. USE 6" WIDE 4 MIL THICK INERT PLASTIC TAPE PRINTED WITH "CAUTION CATHODIC PROTECTION CABLE BELOW."
  - C. PLACE ALL HORIZONTAL AND VERTICAL WIRE RUNS IN SCH 80 PVC CONDUIT WITH SOLVENT WELDED JOINTS @ A MIN OF 3 FEET BELOW FINISHED GRADE. ENCASE IN RED CONCRETE WITH MINIMUM 3" CLEARANCE. CONDUIT NOT SHOWN IN ALL DETAILS FOR CLARITY.
  - D. NUMBER OF ANODES AND TYPE VARIES. ANODES MAY BE INSTALLED ON EITHER SIDE OF THE PIPE MINIMUM 2' AND MAXIMUM 5' FROM PIPE. DO NOT EXCEED THE BOUNDS OF TVWD RIGHT-OF-WAY.
  - E. BACKFILL ANODES WITH CLEAN NATIVE SOIL IN 6-INCH LIFTS. BACKFILL SHALL BE SCREENED AND FREE OF ROCKS LARGER THAN 2 INCHES IN DIAMETER.
  - F. AT CASINGS PLACE ANODES ADJACENT TO NON-ENCASED CARRIER PIPE.
5. BURIED MECHANICAL JOINTS, I.E., VALVES, FLANGES OR COUPLINGS, EXCEPT INSULATING FLANGES, MUST BE BONDED PER DETAILS THIS SET AND WAX TAPED, PER AWWA C217 AND SPECIFICATION.
6. NO WIRE OR CABLE SPLICES ARE PERMITTED.
7. WIRE CONNECTIONS TO PIPE SHALL BE MADE BY THE EXOTHERMIC WELD OR PIN BRAZING PROCESS. ATTACH 1 WIRE PER ATTACHMENT POINT. ALL WELDS MUST BE SEPARATED BY 6" MINIMUM. SEE DETAIL  CP-06
8. COORDINATE AND OBTAIN APPROVAL FROM THE OWNER FOR FOREIGN PIPELINE WIRE ATTACHMENT PRIOR TO INSTALLING FOREIGN TEST STATIONS.
9. CONTRACTOR SHALL DOCUMENT ALL CHANGES FROM THESE DRAWINGS AND SUBMIT "AS-BUILT" DRAWINGS TO THE OWNERS REPRESENTATIVE PRIOR TO COMPLETION OF WORK.

**ABBREVIATIONS:**

#	NUMBER
AASHTO	AMERICAN ASSOCIATION OF STATE HIGHWAY TRANSPORTATION OFFICIALS
BLK	BLACK
BLU	BLUE
BOC	BACK OF CURB
BOV	BLOWOFF VALVE
CARV	COMBINATION AIR RELEASE VALVE
cm	CENTIMETER
CML&TW	CEMENT-MORTAR LINE AND TAPE WRAPPED
CP	CATHODIC PROTECTION
CTS	CORROSION TEST STATION
Cu	COPPER
DW	DOMESTIC WATER
EOP	EDGE OF PAVEMENT
ELEC	ELECTRICAL
EXIST	EXISTING
Fe	IRON
HMWPE	HIGH MOLECULAR WEIGHT POLYETHYLENE
IJ	ISOLATION JOINT
INSUL	INSULATING
LP	LIGHT POLE
Mg	MAGNESIUM
Mn	MANGANESE
MOV	MOTOR OPERATED VALVE
Ni	NICKEL
No	NUMBER
PE	POLYETHYLENE ENCASEMENT
PLCS	PLACES
PB	PULLBOX
PW	POTABLE WATER
QTY.	QUANTITY
RECT	RECTANGULAR
REQ	REQUIRED
RHH-RHW	RUBBER INSULATED HIGH HEAT, AND RUBBER INSULATED HEAT AND WATER RESISTANT
RT	RIGHT
RW	RECYCLED WATER
SPECS	SPECIFICATIONS
SQ.	SQUARE
STA	STATION
STRD	STRANDED
THWN	THERMOPLASTIC HEAT AND WATER RESISTANT NYLON COATED
T.O.P	TOP OF PIPE
VAR	VARIOUS
VV	VALVE VAULT
YLW	YELLOW

STATION	OFFSET	DRAWING	TYPE OF TEST STATION	CP DETAIL/ SHEET	BRASS CAP DETAIL/ SHEET	NO. ANODES	COUPON
280+05	21.0' RT	PP-02	2-WIRE TEST STATION	1/CP-02	1/SD-10	-	X
281+33	24.0' RT	PP-02	4-WIRE ISOLATION FLANGE TEST STATION	4/CP/02	1/SD-10	-	X
285+00	16.5' RT	PP-03	2-WIRE TEST STATION WITH ANODE BED	2/CP-02	1/SD-10	3	X
290+25	16.5' RT	PP-04	2-WIRE TEST STATION WITH ANODE BED	2/CP-02	1/SD-10	3	X
295+50	16.5' RT	PP-05	2-WIRE TEST STATION WITH ANODE BED	2/CP-02	1/SD-10	3	X
298+25	16.5' RT	PP-06	4-WIRE LINE CURRENT TEST STATION	3/CP-02	1/SD-10	-	X
300+75	16.5' RT	PP-06	2-WIRE TEST STATION WITH ANODE BED	2/CP-02	1/SD-10	3	X
306+00	16.5' RT	PP-07	2-WIRE TEST STATION WITH ANODE BED	2/CP-02	1/SD-10	3	X
310+15	16.5' RT	PP-08	4-WIRE ISOLATION FLANGE TEST STATION	4/CP-02	1/SD-10	-	X
311+29	10.0' RT	PP-08	CASING TEST STATION	7/CP-02	1/SD-10	2	X
312+70	10.0' RT	PP-08	CASING TEST STATION	7/CP-02	1/SD-10	2	X
315+47	12.5' RT	PP-09	4-WIRE ISOLATION FLANGE	4/CP-02	1/SD-10	-	X

**CATHODIC PROTECTION EQUIPMENT INSTALLATION SCHEDULE**

NTS

**CATHODIC PROTECTION GENERAL NOTES**

NTS

**CATHODIC PROTECTION ABBREVIATIONS**

NTS

**KNOW WHAT'S BELOW. CALL BEFORE YOU DIG. 811**  
"LOOK UP AND LIVE"

DSGN	B. Clark				
DR	S. Kuhns				
CHK	A. Stevens	4	03/20		
APVD	E. Hadler	0	07/19		
		NO.	DATE	DESIGN CLARIFICATION DC-04 CONFORMED CONSTRUCTION DRAWINGS	
				REVISION	BY APVD

VERIFY SCALE  
BAR IS ONE INCH ON ORIGINAL DRAWING.  
IF NOT ONE INCH ON THIS SHEET, ADJUST SCALES ACCORDINGLY.



PLM\_1.2  
Water Transmission Line  
Schedule B

CATHODIC PROTECTION  
CATHODIC PROTECTION GENERAL NOTES,  
ABBREVIATIONS, AND SCHEDULE

SHEET	20
DWG	CP-01
DATE	03/06/2020
PROJ	PROJ

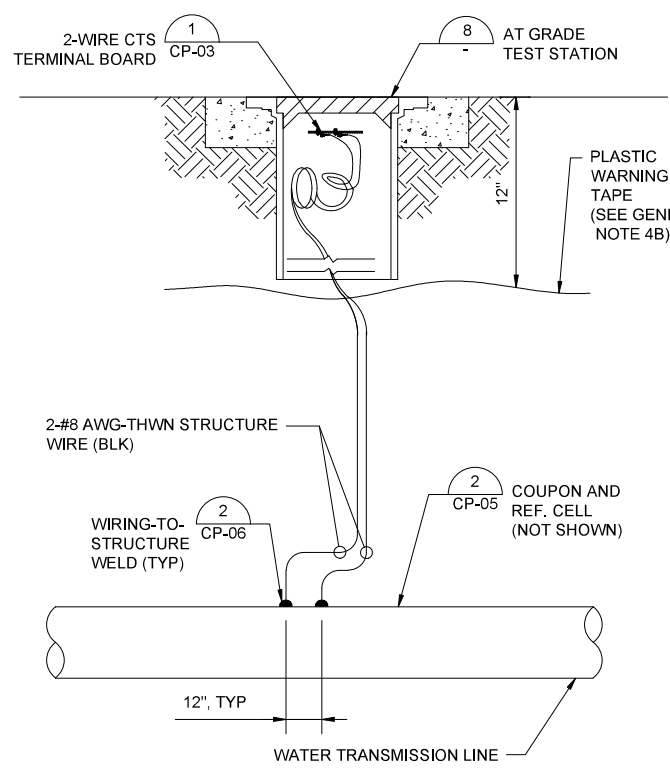

**2-WIRE AT GRADE TEST STATION**  
NTS

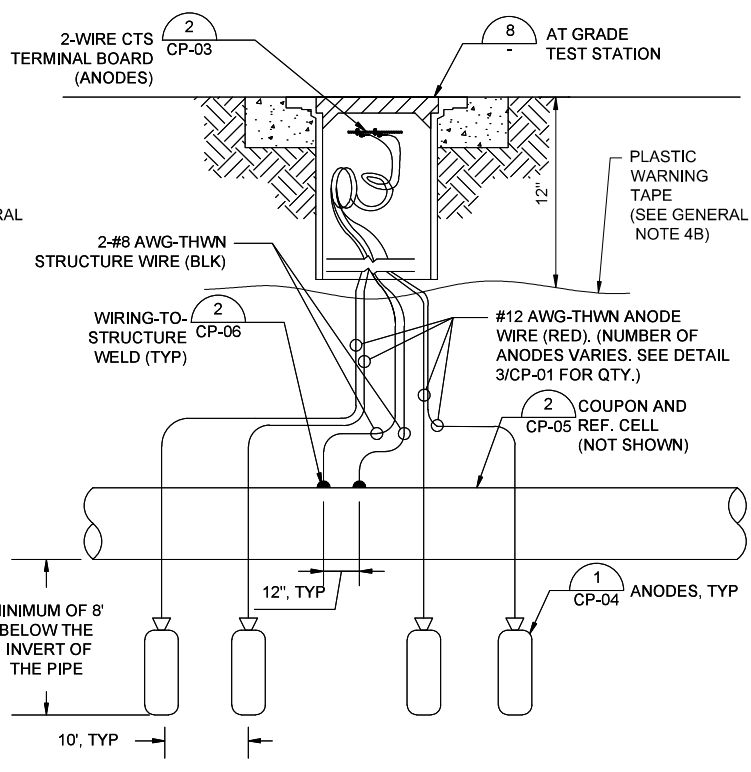

**2-WIRE AT GRADE TEST STATION WITH ANODE BED**  
NTS

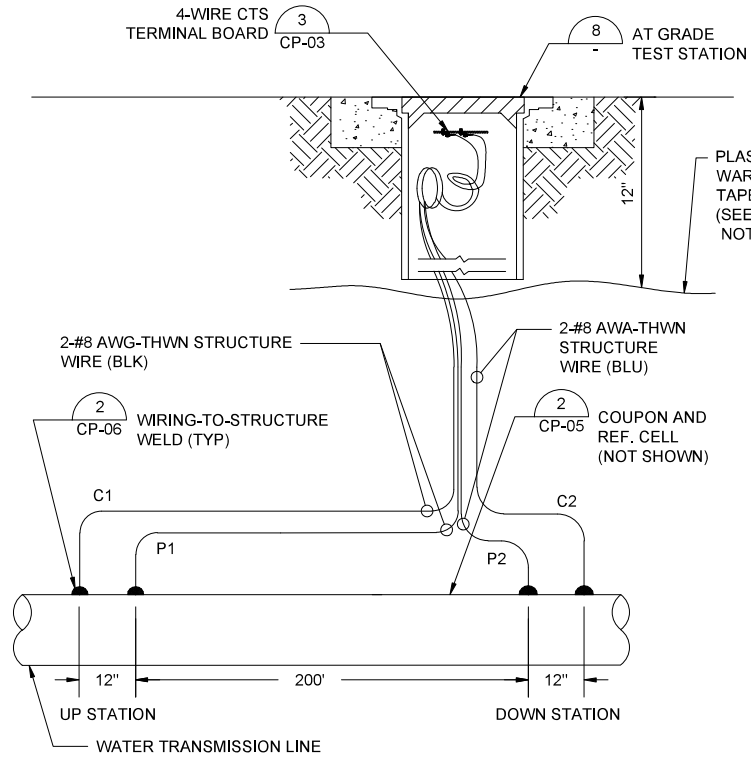

**4-WIRE LINE CURRENT TEST STATION**  
NTS

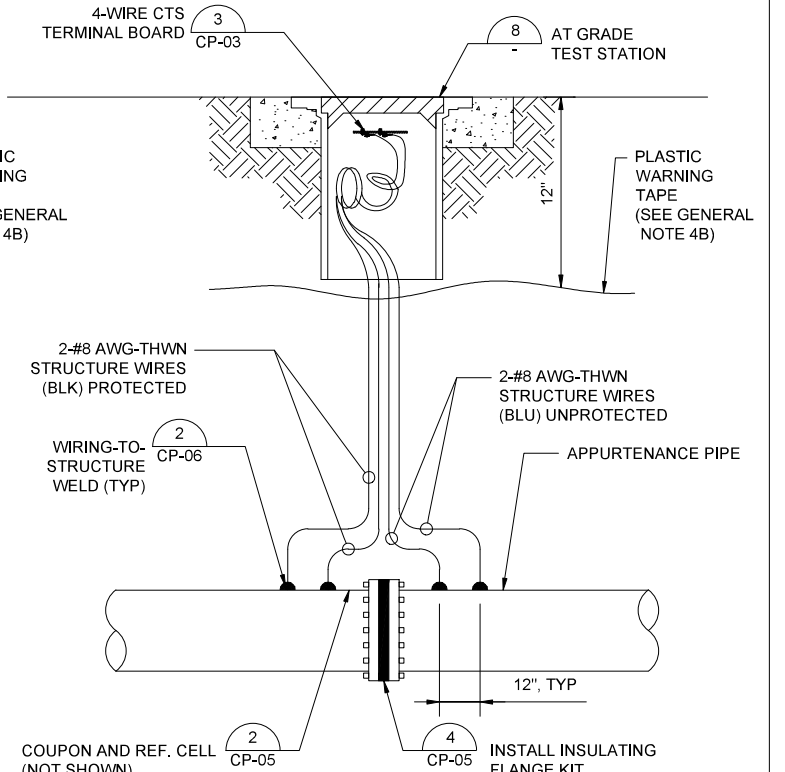

**4-WIRE ISOLATION FLANGE TEST STATION**  
NTS

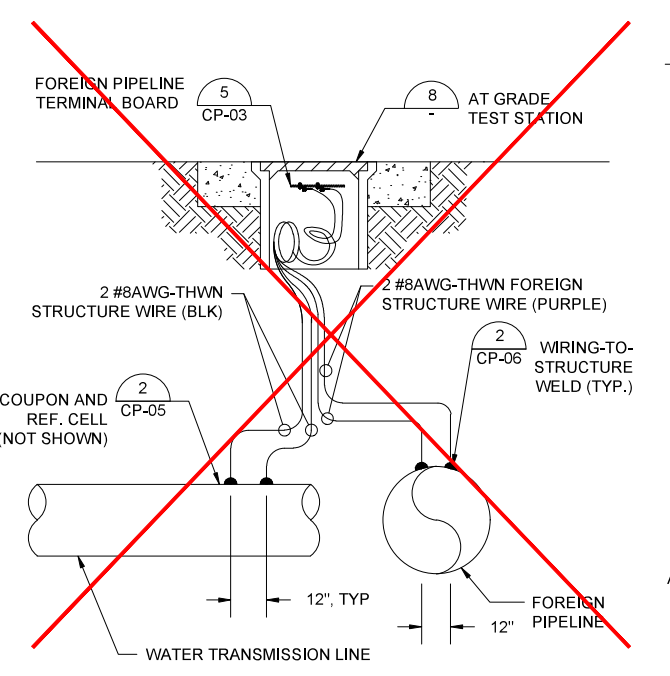

**FOREIGN PIPELINE TEST STATION**  
NTS

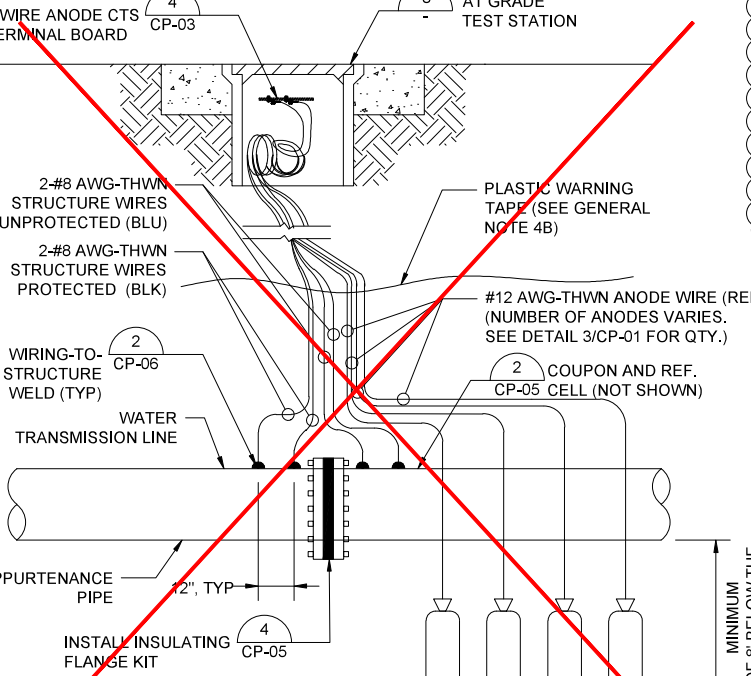

**4-WIRE ISOLATION FLANGE TEST STATION WITH ANODE BED**  
NTS

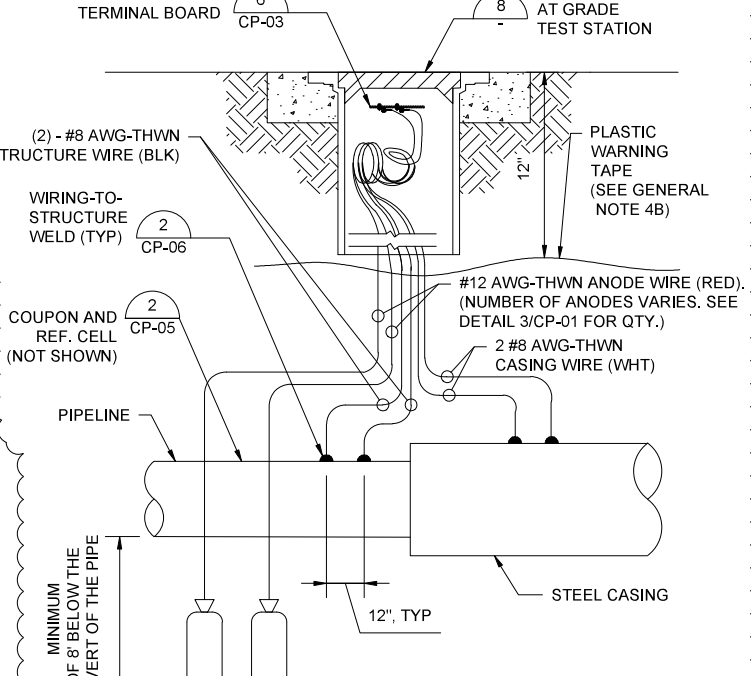

**CASING TEST STATION**  
NTS

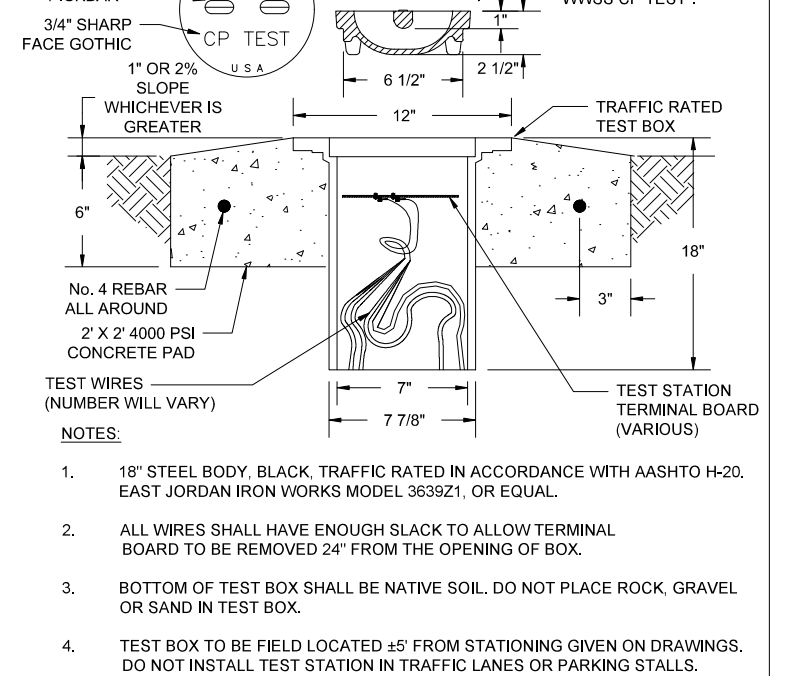

**AT GRADE TEST STATION**  
NTS

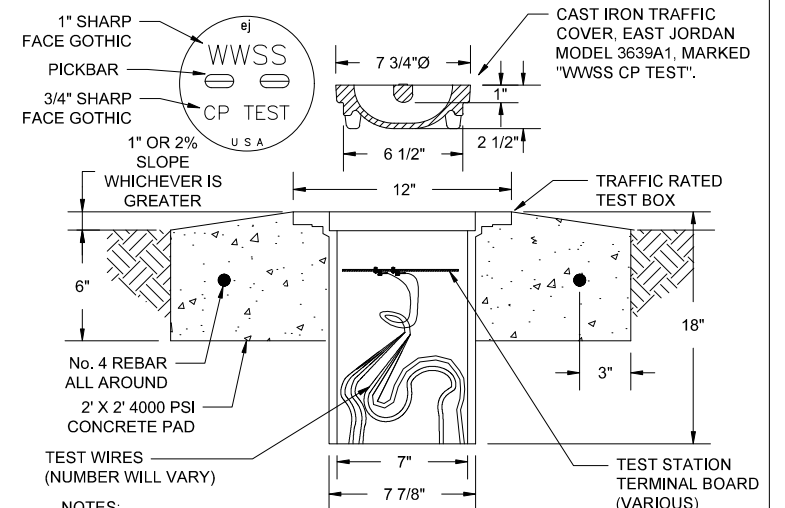

- NOTES:**
- 18" STEEL BODY, BLACK, TRAFFIC RATED IN ACCORDANCE WITH AASHTO H-20, EAST JORDAN IRON WORKS MODEL 3639Z1, OR EQUAL.
  - ALL WIRES SHALL HAVE ENOUGH SLACK TO ALLOW TERMINAL BOARD TO BE REMOVED 24" FROM THE OPENING OF BOX.
  - BOTTOM OF TEST BOX SHALL BE NATIVE SOIL. DO NOT PLACE ROCK, GRAVEL OR SAND IN TEST BOX.
  - TEST BOX TO BE FIELD LOCATED ±5' FROM STATIONING GIVEN ON DRAWINGS. DO NOT INSTALL TEST STATION IN TRAFFIC LANES OR PARKING STALLS.
  - WRAP ENTIRE EXTERIOR OF STEEL BODY WITH POLYETHYLENE TAPE PRIOR TO CASTING CONCRETE PAD. POLYKEN #930, OR EQUAL.
  - PROVIDE SUFFICIENT SLOPING IN THE CONCRETE PAD OR SURROUNDING PAVEMENT TO PROVIDE DRAINAGE AWAY FROM TEST BOX.

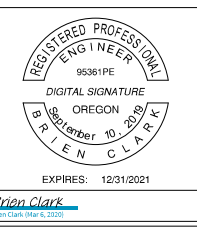

**KNOW WHAT'S BELOW. CALL BEFORE YOU DIG. 811**  
"LOOK UP AND LIVE"

DSGN	B. Clark				
DR	S. Kuhns	4	03/20	DESIGN CLARIFICATION DC-04	
CHK	A. Stevens	3	02/20	DESIGN CLARIFICATION DC-03	
APVD	E. Hadler	0	07/19	CONFORMED CONSTRUCTION DRAWINGS	
		NO.	DATE	REVISION	BY
					APVD

VERIFY SCALE  
BAR IS ONE INCH ON ORIGINAL DRAWING.  
IF NOT ONE INCH ON THIS SHEET, ADJUST SCALES ACCORDINGLY.



PLM\_1.2  
Water Transmission Line  
Schedule B

CATHODIC PROTECTION  
CATHODIC PROTECTION  
DETAILS I

SHEET	21
DWG	CP-02
DATE	03/06/2020
PROJ	PROJ

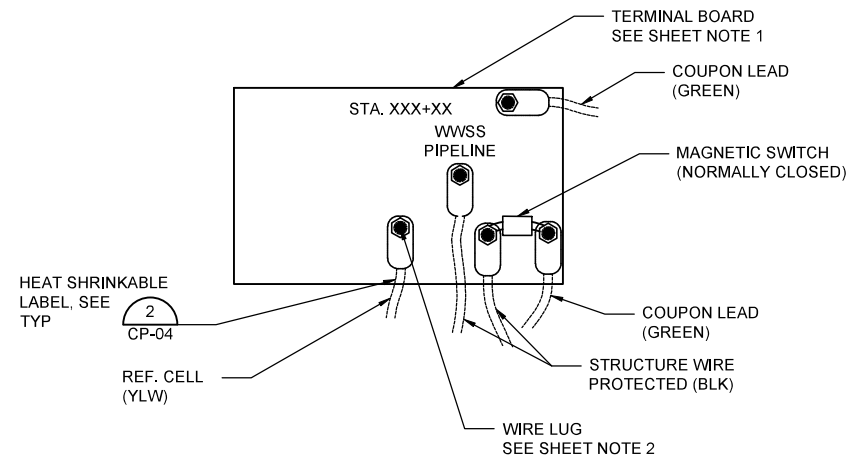

**2-WIRE TERMINAL BOARD**  
NTS

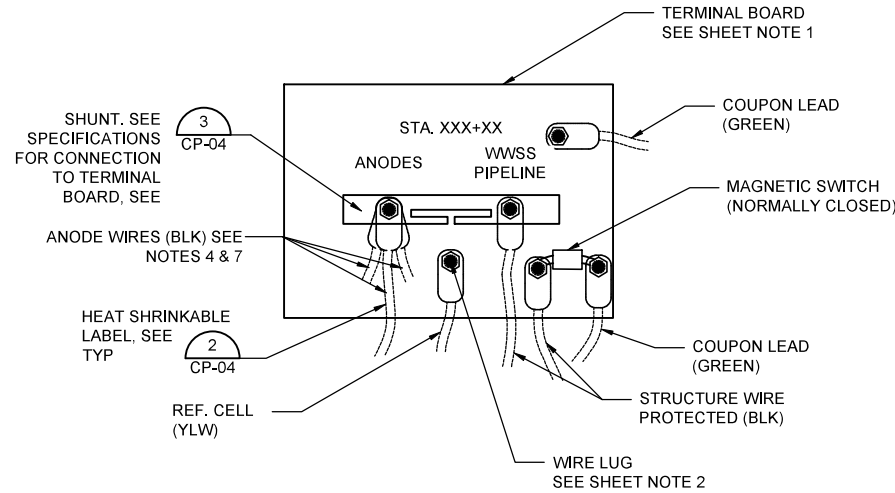

**2-WIRE TERMINAL BOARD WITH ANODES**  
NTS

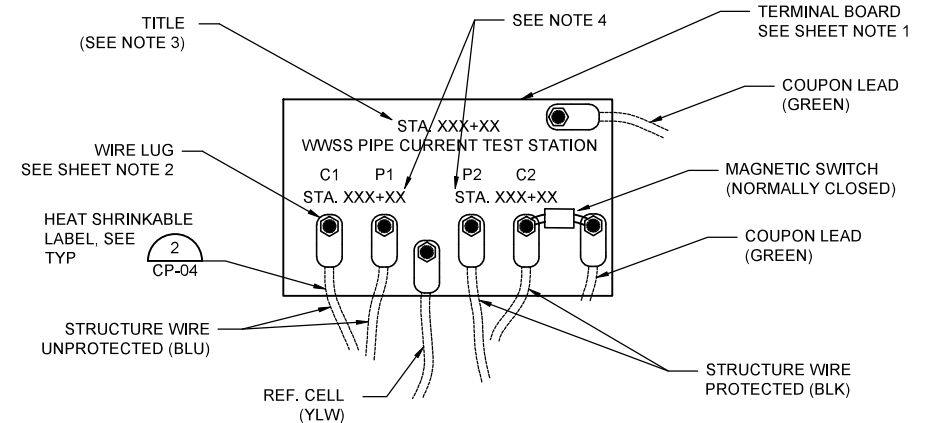

**NOTES:**

- 4-WIRE LINE CURRENT TEST STATION: CONNECT COUPON TO DOWN STATION (LOCAL) WIRE.
- 4-WIRE ISOLATION TEST STATION: CONNECT COUPON TO PROTECTED SIDE OF IJ.
- AT LINE CURRENT TEST STATION TITLE "CURRENT TEST STATION" AS SHOWN. AT ISOLATION TEST STATION TITLE "ISOLATION TEST STATION" INSTEAD.
- DUAL STA ONLY APPLIES TO LINE CURRENT TEST STATION. STATIONING IS BASED ON THE PIPE STATION WHERE THE WIRES ARE ATTACHED TO THE PIPE.

**4-WIRE TERMINAL BOARD**  
NTS

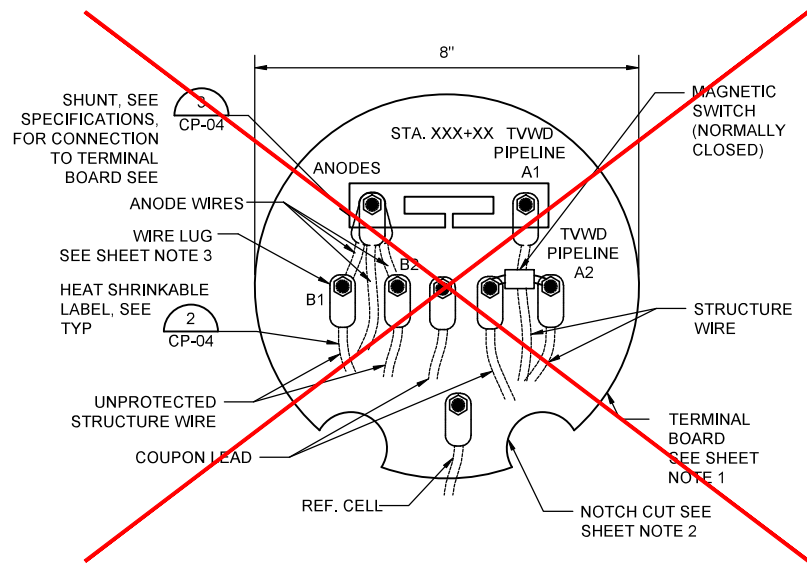

**4-WIRE ISOLATION/ANODE TERMINAL BOARD**  
NTS

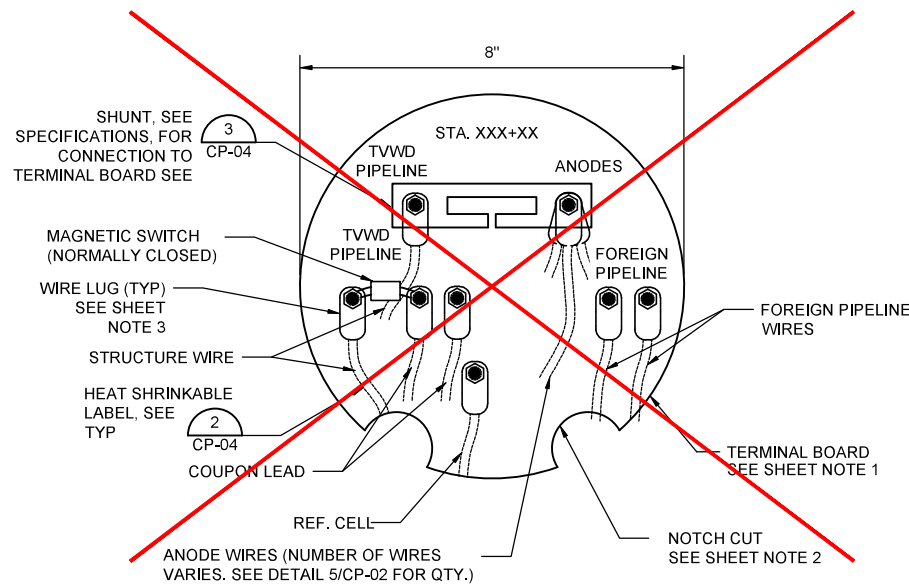

**FOREIGN PIPELINE TERMINAL BOARD WITH ANODES**  
NTS

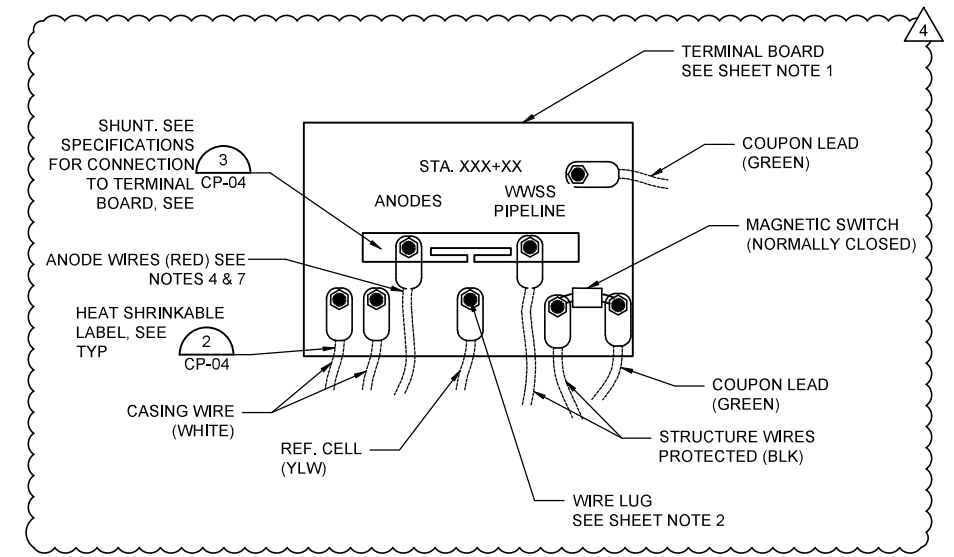

**CASING TERMINAL BOARD WITH ANODES**  
NTS

**SHEET NOTES:**

- PHENOLIC TERMINAL BOARD, 1/4" THICK, 6" x 3.5" MAX. TO FIT AT GRADE TEST STATION.
- SOLDERLESS WIRE LUG, ILSCO CP-4 OR EQUAL
- USE THE APPROPRIATE TERMINAL BOARD AT EACH TEST STATION AS SPECIFIED IN THE PLAN SHEETS.
- INSTALL ANODES ON UNDERSIDE OF TERMINAL BOARD
- NO STEEL OR STAINLESS STEEL SUBCOMPONENTS
- ALL LETTERING TO BE ENGRAVED ON TERMINAL BOARD
- NUMBER OF ANODES WILL VARY PER LOCATION, SEE SHEET CP-01.

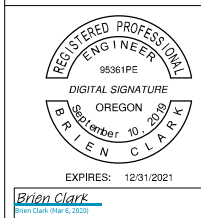

**KNOW WHAT'S BELOW.  
CALL BEFORE YOU DIG. 811**  
"LOOK UP AND LIVE"

NO.	DATE	REVISION	BY	APVD
4	03/20	DESIGN CLARIFICATION DC-04		
3	02/20	DESIGN CLARIFICATION DC-03		
0	07/19	CONFORMED CONSTRUCTION DRAWINGS		
DSGN	B. Clark			
DR	S. Kuhns			
CHK	A. Stevens			
APVD	E. Hadler			

**VERIFY SCALE**  
BAR IS ONE INCH ON ORIGINAL DRAWING.  
IF NOT ONE INCH ON THIS SHEET, ADJUST SCALES ACCORDINGLY.



PLM\_1.2  
Water Transmission Line  
Schedule B

CATHODIC PROTECTION  
CATHODIC PROTECTION  
DETAILS II

SHEET 22  
DWG CP-03  
DATE 03/06/2020  
PROJ PROJ



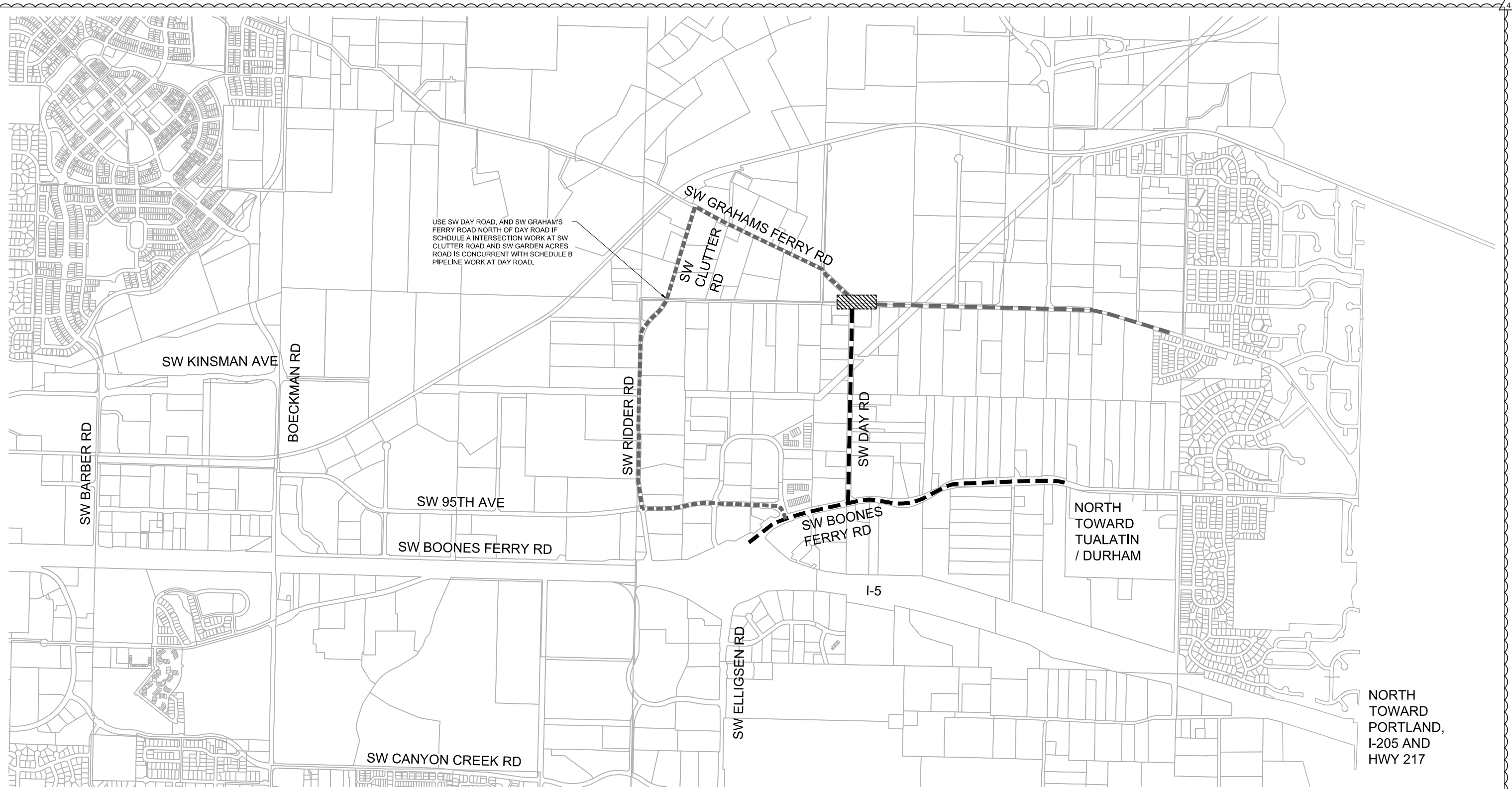

TEMPORARY TRAFFIC CONTROL LEGEND:

AREA UNDER CONSTRUCTION, SEE SHEET TC-03 FOR TCP

HAUL ROUTE LEGEND:

PRIMARY HAUL ROUTE  
 SECONDARY HAUL ROUTE



NORTH TOWARD PORTLAND, I-205 AND HWY 217

NORTH TOWARD TUALATIN / DURHAM

**KNOW WHAT'S BELOW. CALL BEFORE YOU DIG. 811**  
 "LOOK UP AND LIVE"

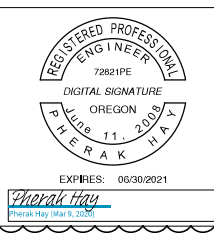

DSGN	P. Hay						
DR	M. Sennewald						
CHK	B. LeBlanc	4	03/20	DESIGN CLARIFICATION DC-04			
APVD	E. Hadler	NO.	DATE	REVISION	BY	APVD	

VERIFY SCALE  
 BAR IS ONE INCH ON ORIGINAL DRAWING.  
 IF NOT ONE INCH ON THIS SHEET, ADJUST SCALES ACCORDINGLY.



**Willamette Water Supply**  
 Our Reliable Water







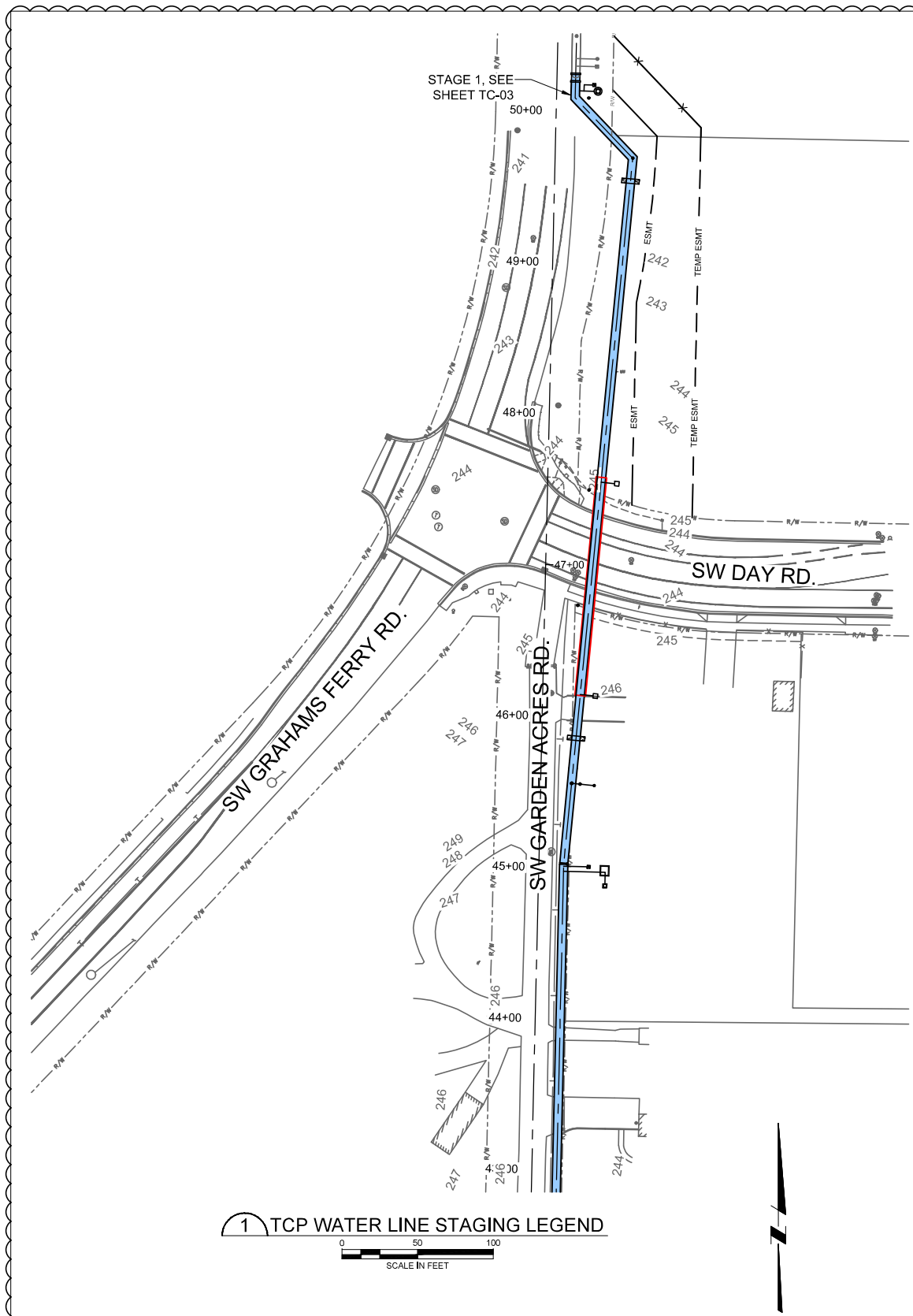





PLM\_1.2  
 Water Transmission Line  
 Schedule B

TRAFFIC CONTROL  
 TRAFFIC CONTROL PLANS  
 VICINITY MAP AND HAUL ROUTE

SHEET	41
DWG	TC-01
DATE	03/06/2020
PROJ	PROJ



**TEMPORARY TRAFFIC CONTROL LEGEND:**

-  TEMPORARY DIRECTION OF TRAVEL
-  TEMPORARY CONCRETE BARRIER, SEE ODOT STD. DWG. TM830, OR APPROVED EQUIVALENT.
-  TP/DT TUBULAR MARKERS, FROM ODOT'S APPROVED QUALIFIED PRODUCTS LIST. SPACING PER ODOT STD. DWG. TM800.
-  TP/DT BARRELS, FROM ODOT'S APPROVED QUALIFIED PRODUCT LIST. SPACING PER ODOT STD. DWG. TM800.
-  PEDESTRIAN CHANNELIZATION DEVICE, FROM ODOT'S APPROVED QUALIFIED PRODUCTS LIST
-  AREA UNDER TRAFFIC
-  AREA UNDER CONSTRUCTION
-  SIGN, SEE ODOT STD. DWG. TM821 AND TM822 FOR SIGN SUPPORT
-  SIGN ON TEMPORARY SIGN SUPPORT (TSS), SEE ODOT STD. DWG. TM821
-  TYPE III BARRICADE ON TSS, SEE ODOT STD. DWG. TM820
-  NARROW-SITE TEMP IMPACT ATTENUATOR, FROM ODOT'S APPROVED QUALIFIED PRODUCT LIST
-  TEMPORARY IMPACT ATTENUATOR FROM ODOT'S APPROVED QUALIFIED PRODUCTS LIST, SEE ODOT STD. DWG. TM831
-  FLAGGER

**GENERAL NOTES:**

1. SEE SHEET TC-03 FOR TRAFFIC CONTROL WORK.
2. TEMPORARY TRAFFIC CONTROL DEVICES:
  - 2.1. SIGNAGE SHALL BE MAINTAINED THROUGHOUT THE DURATION OF PROJECT.
  - 2.2. BARRICADES, BARRIERS, AND TEMPORARY SIGNS SHOULD BE PLACED WHERE SHOWN IN THE PLANS. EXACT LOCATIONS SHALL BE DETERMINED AND VERIFIED BY THE PROJECT TRAFFIC CONTROL SUPERVISOR.
3. BUSINESS ACCESS :
  - 3.1. CONTRACTOR SHALL PROVIDE ACCESS TO ADJACENT BUSINESSES AT ALL TIMES DURING CONSTRUCTION, AND COORDINATE ANY IMPACTS TO ACCESS WITH ADJACENT BUSINESSES PRIOR TO ANY IMPROVEMENTS.
4. EXISTING SIGNS AND PAVEMENT MARKINGS THAT CONFLICT WITH TEMPORARY TRAFFIC CONTROL OPERATIONS, WITH APPROVAL OF ENGINEER, WILL BE COVERED FOR THE DURATION OF OPERATION. RETURN PAVEMENT MARKINGS AND SIGNAGES TO ORIGINAL CONDITION ONCE TRAFFIC RETURNS TO NORMAL OPERATION.
5. EMERGENCY RESPONDERS:
  - 5.1. EMERGENCY RESPONDERS, INCLUDING FIRE TRUCKS, AMBULANCES, AND LAW ENFORCEMENT, SHALL HAVE PRIORITY THROUGH THE WORK ZONE AT ALL TIMES.
6. STAGING PLANS:
  - 6.1. SIGNAGES, TRAFFIC CONTROL DEVICES, AND OTHER TRAFFIC CONTROL MEASURES SHOWN IN THESE PLAN SHEETS ARE GRAPHICALLY SHOWN TO DEPICT THE MINIMUM STAGING REQUIREMENT. ADDITIONAL TRAFFIC CONTROL MEASURES MAY BE REQUIRED.
  - 6.2. TRAFFIC CONTROL MANAGER SHALL COORDINATE WORK ZONE STAGING WITH CONTRACTOR FOR SITE SPECIFIC ACTIVITIES.
7. TEMPORARY PEDESTRIAN ACCESSIBLE ROUTES (TPAR) AND BIKE LANES:
  - 7.1. SEE ODOT STD. DWG. TM844 FOR TYPICAL PEDESTRIAN DETOUR ROUTE FOR CROSSWALK CLOSURE.
  - 7.2. CONTRACTOR SHALL PROVIDE TEMPORARY PEDESTRIAN ACCESSIBLE ROUTES THROUGH AND/OR AROUND WORK ZONE AT ALL TIMES.
  - 7.3. TEMPORARY PEDESTRIAN FACILITIES SHALL NOT EXCEED A CROSS SLOPE OF 2% AND SHALL BE FLUSH WHERE IT ABUTS TO THE EXISTING SIDEWALK.
  - 7.4. TEMPORARY BIKE LANES SHALL EITHER BE ACCOMMODATED OR ROUTE WITH VEHICLE TRAVEL LANE WITH PROPER SIGNAGE.
8. WATERLINE TRENCH WORK:
  - 8.1. TCP CONCEPT ASSUMED A 3'-5" MINIMUM SPACING BETWEEN END OF WATERLINE PIPE SECTION AND SHORING WALL, AND A MINIMUM 3'-5" SPACING BETWEEN SHORING WALL AND FACE OF BARRIER. ADDITIONAL SPACING MAY BE REQUIRED PER OSHA, SHORING WALL REQUIREMENTS AND/OR FIELD CONDITIONS. CONTRACTOR TO ADJUST THE TCP AS NEEDED TO ACCOMMODATE FOR CONSTRUCTION MEANS AND METHODS.
9. POSTED SPEED:
  - 9.1. SW GRAHAMS FERRY RD POSTED SPEED 45 MPH.
  - 9.2. SW DAY RD POSTED SPEED 40 MPH.
  - 9.3. PRIVATE DRIVE POSTED SPEED 15MPH.
10. REFERENCES, STANDARDS, GUIDANCE, AND REQUIREMENTS:
  - 10.1. REFERENCE ODOT SIGN POLICY MANUAL, CHAPTER 6 FOR MORE INFORMATION ON SIGN REQUIREMENTS.
  - 10.2. COMPLY WITH ODOT'S "TRAFFIC CONTROL PLANS DESIGN MANUAL"
  - 10.3. COMPLY WITH ODOT'S "OREGON TEMPORARY TRAFFIC CONTROL HAND BOOK FOR OPERATIONS OF THREE DAYS OR LESS" MANUAL, FOR WORK REQUIRED DEVICES IN PLACE FOR 3-DAYS OR LESS.

1 TCP WATER LINE STAGING LEGEND  
SCALE IN FEET



**KNOW WHAT'S BELOW. CALL BEFORE YOU DIG. 811**  
"LOOK UP AND LIVE"

DSGN	P. Hay						
DR	M. Sennewald						
CHK	B. LeBlanc	4	03/20	DESIGN CLARIFICATION DC-04			
APVD	E. Hadler	NO.	DATE	REVISION	BY	APVD	

VERIFY SCALE  
BAR IS ONE INCH ON ORIGINAL DRAWING.  
IF NOT ONE INCH ON THIS SHEET, ADJUST SCALES ACCORDINGLY.



PLM\_1.2  
Water Transmission Line  
Schedule B

TRAFFIC CONTROL  
TRAFFIC CONTROL PLANS  
LEGENDS AND GENERAL NOTES

SHEET	42
DWG	TC-02
DATE	03/06/2020
PROJ	PROJ

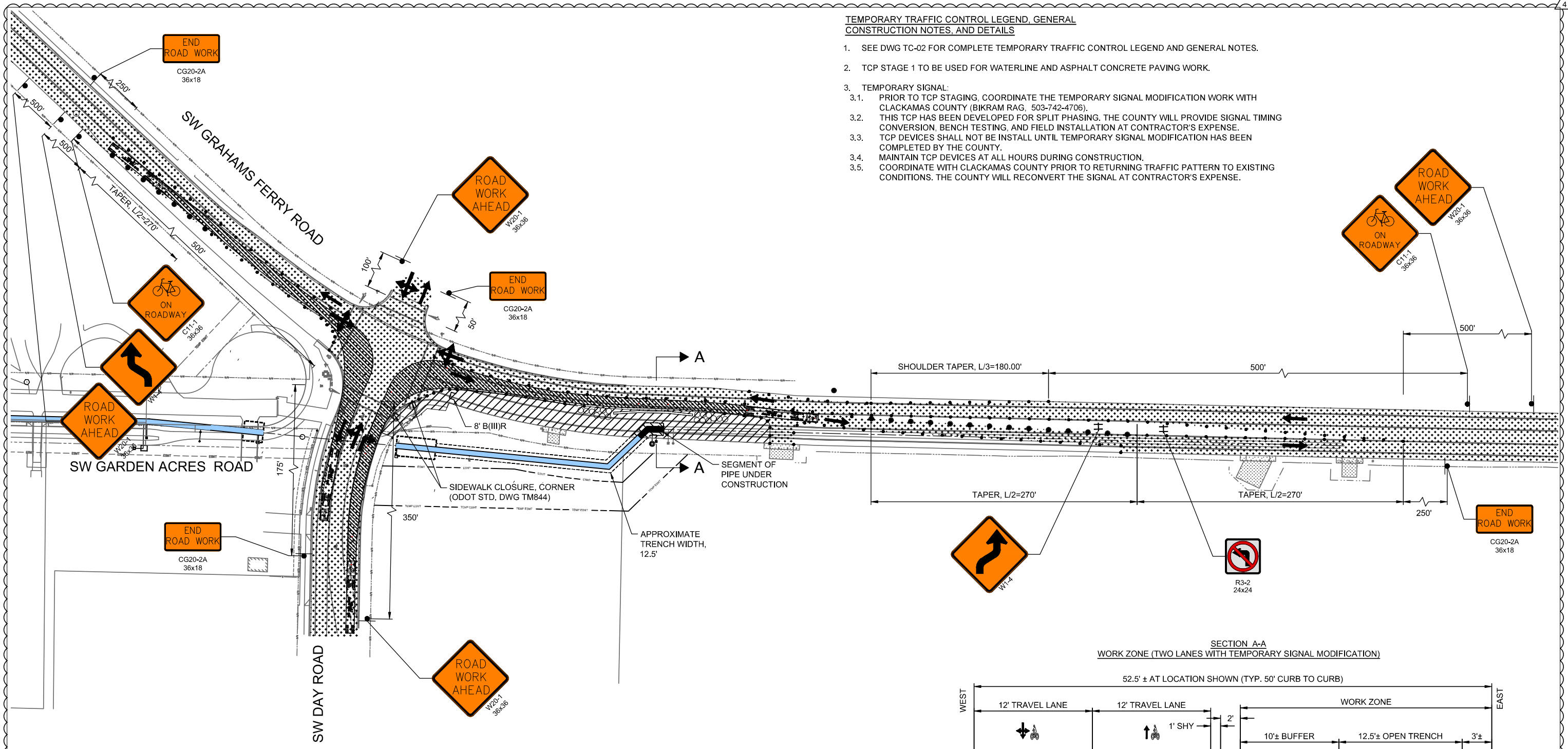

- TEMPORARY TRAFFIC CONTROL LEGEND, GENERAL CONSTRUCTION NOTES, AND DETAILS**
- SEE DWG TC-02 FOR COMPLETE TEMPORARY TRAFFIC CONTROL LEGEND AND GENERAL NOTES.
  - TCP STAGE 1 TO BE USED FOR WATERLINE AND ASPHALT CONCRETE PAVING WORK.
  - TEMPORARY SIGNAL:
    - PRIOR TO TCP STAGING, COORDINATE THE TEMPORARY SIGNAL MODIFICATION WORK WITH CLACKAMAS COUNTY (BIKRAM RAG, 503-742-4706).
    - THIS TCP HAS BEEN DEVELOPED FOR SPLIT PHASING. THE COUNTY WILL PROVIDE SIGNAL TIMING CONVERSION, BENCH TESTING, AND FIELD INSTALLATION AT CONTRACTOR'S EXPENSE.
    - TCP DEVICES SHALL NOT BE INSTALL UNTIL TEMPORARY SIGNAL MODIFICATION HAS BEEN COMPLETED BY THE COUNTY.
    - MAINTAIN TCP DEVICES AT ALL HOURS DURING CONSTRUCTION.
    - COORDINATE WITH CLACKAMAS COUNTY PRIOR TO RETURNING TRAFFIC PATTERN TO EXISTING CONDITIONS. THE COUNTY WILL RECONVERT THE SIGNAL AT CONTRACTOR'S EXPENSE.

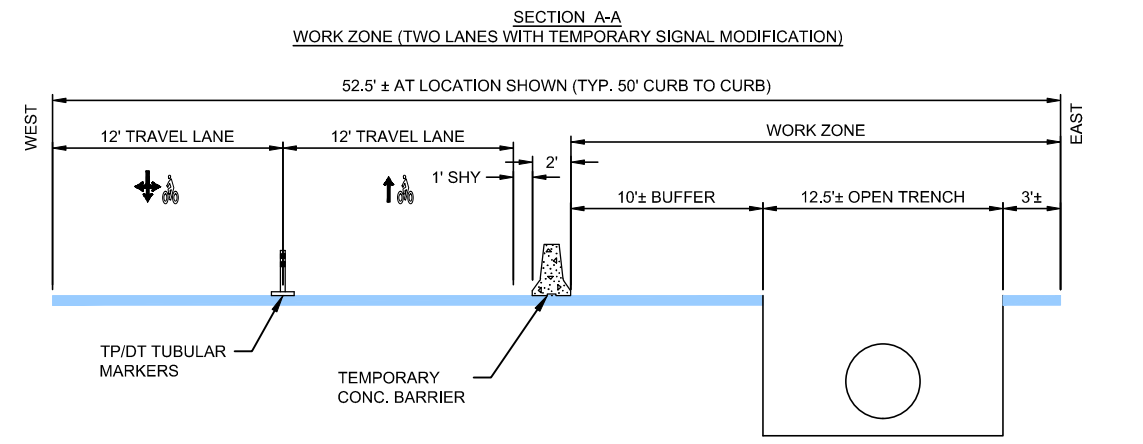
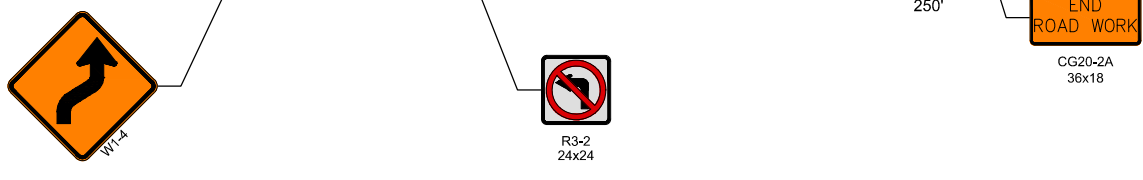

**STAGE 1 - ALL HOURS**

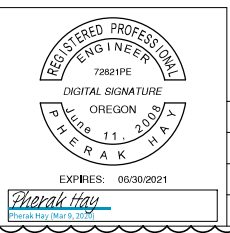

**KNOW WHAT'S BELOW. CALL BEFORE YOU DIG. 811**  
"LOOK UP AND LIVE"

DSGN					
DR					
CHK	4	03/20	DESIGN CLARIFICATION DC-04		
APVD	NO.	DATE	REVISION	BY	APVD



**VERIFY SCALE**  
BAR IS ONE INCH ON ORIGINAL DRAWING.  
IF NOT ONE INCH ON THIS SHEET, ADJUST SCALES ACCORDINGLY.



**Willamette Water Supply**  
Our Reliable Water

PLM\_1.2  
Water Transmission Line  
Schedule B

SHEET	
DWG	
DATE	03/06/2020
PROJ	

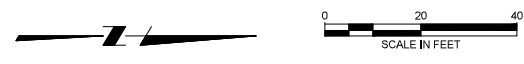
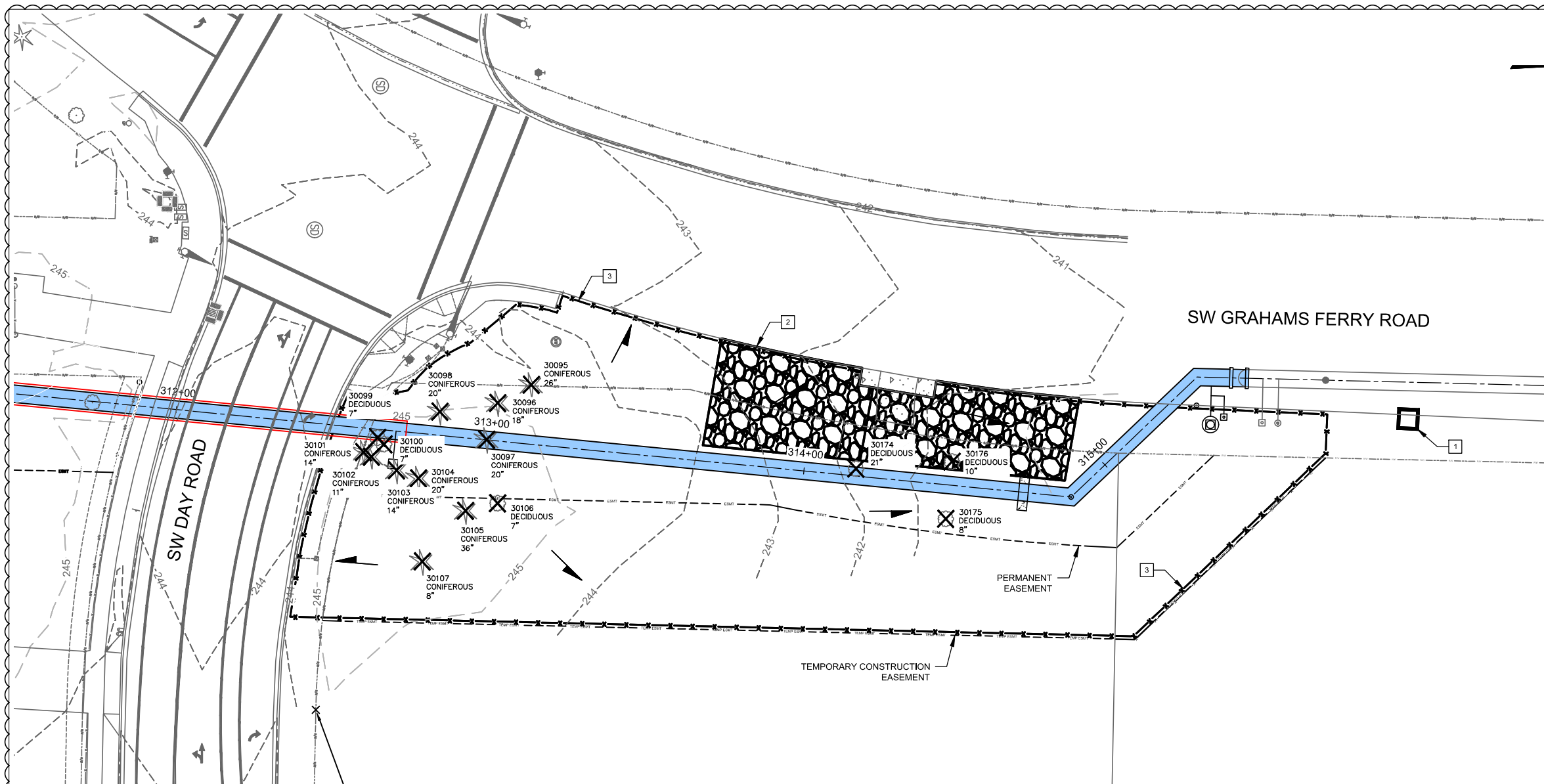

**EROSION AND SEDIMENT CONTROL NOTES:**

- 1 EXTG. STORM CURB INLET TO BE PROTECTED. SEE DETAILS S-2126 AND S-2127 IN GARDEN ACRES ROAD SCHEDULE A SHEET EC-17. FIELD VERIFY INLET TYPE AND APPLY APPROPRIATE INLET PROTECTION.
- 2 INSTALL GRAVEL CONSTRUCTION ENTRANCE. SEE DETAIL S-2240 IN GARDEN ACRES ROAD SCHEDULE A SHEET EC-17.
- 3 INSTALL SEDIMENT FENCE. SEE DETAIL S-2245 IN DWG EC-02.

**EROSION AND SEDIMENT CONTROL NOTES:**

1. SEE GARDEN ACRES ROAD SCHEDULE A SHEET EC-02 AND SCHEDULE A SPECIFICATION 00320. CLEARING AND GRUBBING. FOR STANDARD EROSION AND SEDIMENT CONTROL PLAN DRAWING NOTES.
2. REMOVE TREES WHERE INDICATED IN ACCORDANCE WITH SCHEDULE A AND SPECIFICATION SECTION 00320. CLEARING AND GRUBBING.

**TREE RECONNAISSANCE NOTES:**

1. TREES (13) 30095 TO 30107 ARE PART OF A VERY DENSE STAND OF TREES CONSISTING OF BIGLEAF MAPLES AND MATURE DOUGLAS FIR, SURROUNDED BY DENSE POISON OAK. GENERAL CONDITION OF THE GROUP OF TREES IS FAIR.
2. TREES (3) 30174, 30175, AND 30176 ARE PART OF A GROUP OF TREES CONSISTING OF ENGLISH WALNUT (FAIR CONDITION), PLUM (POOR CONDITION), AND VARIOUS LILAC SHRUBS AND BLACKBERRIES.

**EROSION CONTROL LEGEND:**

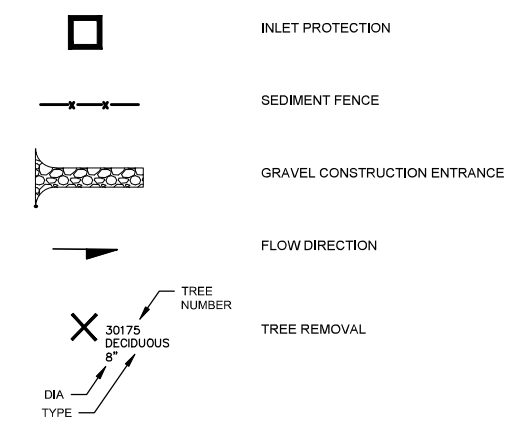

**KNOW WHAT'S BELOW. CALL BEFORE YOU DIG. 811**  
"LOOK UP AND LIVE"

DSGN	P. Hay						
DR	M. Sennewald						
CHK	B. LeBlanc	4	03/20	DESIGN CLARIFICATION DC-04			
APVD	E. Hadler	NO.	DATE	REVISION	BY	APVD	

**VERIFY SCALE**  
BAR IS ONE INCH ON ORIGINAL DRAWING.  
IF NOT ONE INCH ON THIS SHEET, ADJUST SCALES ACCORDINGLY.



PLM\_1.2  
Water Transmission Line  
Schedule B

EROSION CONTROL AND FENCING  
**EROSION AND SEDIMENT CONTROL PLAN**

SHEET	44
DWG	EC-01
DATE	03/06/2020
PROJ	PROJ

This Detail Drawing may not be altered or changed in any manner except by the City Engineer. It is the responsibility of the user to acquire the most current version.

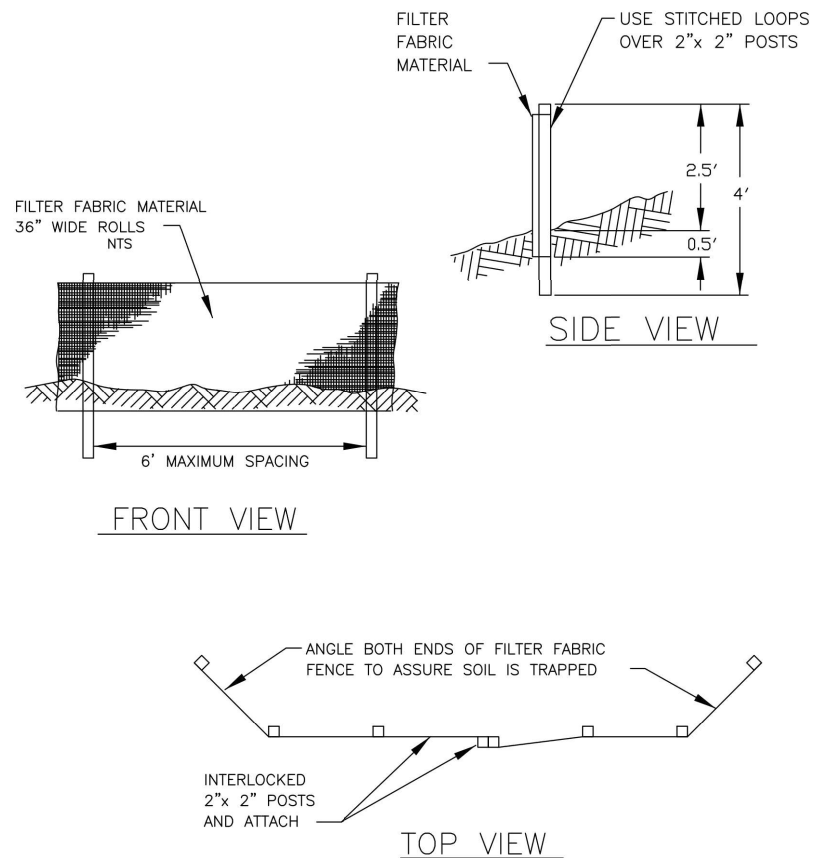

- NOTE:
1. SEDIMENT FENCING SHALL BE INSTALLED AS PER MANUFACTURER RECOMMENDATIONS.
  2. BURY BOTTOM OF FILTER FABRIC 6" MIN. VERTICALLY BELOW GRADE.
  3. 2" X 2" FIR, PINE, OR STEEL FENCE POSTS.
  4. STITCHED LOOPS TO BE INSTALLED UPHILL SIDE OF SLOPE.
  5. COMPACT NATIVE FILL IN ALL AREAS OF FILTER FABRIC TRENCH.

Sediment Fence			CITY OF WILSONVILLE PUBLIC WORKS STANDARDS
DRAWING NUMBER: S-2245	DRAWN BY: SR	SCALE: N.T.S.	
FILE NAME: S-2245.DWG	APPROVED BY: NK	DATE: 9/17/14	

This Detail Drawing may not be altered or changed in any manner except by the City Engineer. It is the responsibility of the user to acquire the most current version.

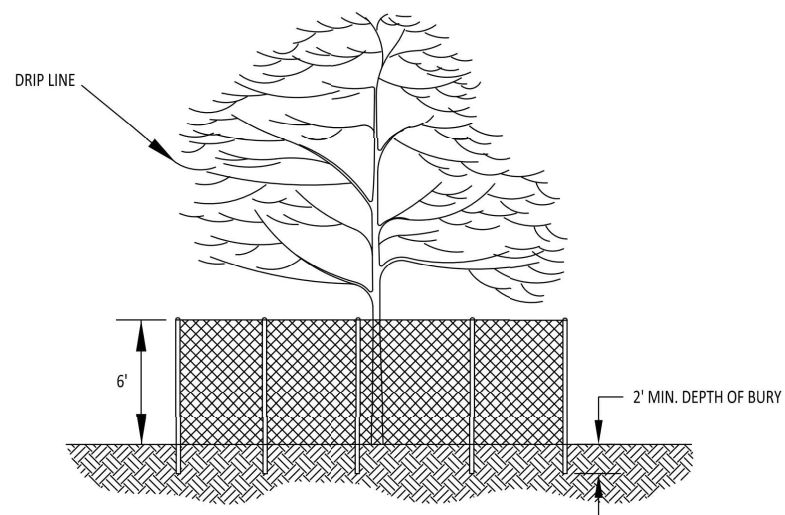

- NOTES:
1. FENCE SHALL BE 6' IN HEIGHT AND SET AT TREE DRIP LINE.
  2. FENCE MATERIALS SHALL CONSIST OF 2" MESH CHAIN LINKS SECURED TO A MINIMUM 1 1/2" DIA. STEEL OR ALUMINUM LINE POSTS.
  3. POSTS SHALL BE SET TO A DEPTH OF NO LESS THAN 2 FEET IN NATIVE SOIL.
  4. FENCE SHALL REMAIN IN PLACE UNTIL THE COMPLETION OF CONSTRUCTION ACTIVITIES. MOVEMENT OR REMOVAL OF FENCE REQUIRES APPROVAL BY CITY'S AUTHORIZED REPRESENTATIVE.

Tree Protection Fencing			CITY OF WILSONVILLE PUBLIC WORKS STANDARDS
DRAWING NUMBER: RD-1230	DRAWN BY: SR	SCALE: N.T.S.	
FILE NAME: RD-1230.DWG	APPROVED BY: NK	DATE: 4/2/14	



**KNOW WHAT'S BELOW. CALL BEFORE YOU DIG. 811**  
"LOOK UP AND LIVE"

DSGN	P. Hay					
DR	M. Sennewald					
CHK	B. LeBlanc	4	03/20	DESIGN CLARIFICATION DC-04		
APVD	E. Hadler	NO.	DATE	REVISION	BY	APVD

VERIFY SCALE  
BAR IS ONE INCH ON ORIGINAL DRAWING.  
0 1"  
IF NOT ONE INCH ON THIS SHEET, ADJUST SCALES ACCORDINGLY.



**Willamette Water Supply**  
Our Reliable Water

PLM\_1.2  
Water Transmission Line  
Schedule B

EROSION CONTROL AND FENCING  
CITY OF WILSONVILLE STANDARD  
EROSION AND SEDIMENT CONTROL DETAILS

SHEET	45
DWG	EC-02
DATE	03/06/2020
PROJ	PROJ

# DESIGN CLARIFICATION DC-04

## Willamette Water Supply Program PLM 1.2 Schedule B

### Supplemental Specifications

The supplemental specifications contained herein are supplemental to the technical specifications and related contract requirements of Schedule B of the City of Wilsonville's Garden Acres Road / PLM 1.2 Project (File No. 17 04 002, CIP #4201).

March 6, 2020

CERTIFICATE OF ENGINEER

---

The technical material and data contained herein were prepared under the supervision and direction of the undersigned, whose seal, as a professional engineer licensed to practice as such, is affixed below.

DIVISION 01 – GENERAL REQUIREMENTS

01 56 26 FENCING AND SITE SECURITY

01 56 39 TEMPORARY TREE AND PLANT PROTECTION



EXPIRES: 12/31/2019

Daniel Applegate  
Daniel Applegate (Mar 6, 2020)

01 57 00 ENVIRONMENTAL CONTROLS

01 57 13 TEMPORARY EROSION AND SEDIMENT CONTROL



EXPIRES: 06/30/2021

Pherak Hay  
Pherak Hay (Mar 9, 2020)

CERTIFICATE OF ENGINEER

---

The technical material and data contained herein were prepared under the supervision and direction of the undersigned, whose seal, as a professional engineer licensed to practice as such, is affixed below.

DIVISION 31 – EARTHWORK

31 09 00 INSTRUMENTATION AND MONITORING

31 41 00 SHAFT EXCAVATION AND SUPPORT

DIVISION 33 – UTILITIES

33 05 23.16 TRENCHLESS CONSTRUCTION

33 05 23.20 STEEL CASING PIPE



EXPIRES: 12/31/2020

  
yuxin lang (Mar 9, 2020)





## **SECTION 01 56 26 FENCING AND SITE SECURITY**

### **PART 1 - GENERAL**

#### **1.1 SUMMARY**

- A. Provide permanent and temporary fencing and security as required meeting the requirements of this Section.

### **PART 2 - PRODUCTS (NOT USED)**

### **PART 3 - EXECUTION**

#### **3.1 GENERAL**

- A. Provide security measures necessary to safeguard the public, schoolchildren, residents, property owners and/or property owners' livestock from construction activities, staging areas, equipment, and materials. Provide temporary fencing when necessary. Fence will be utilized in a way that protects safety and limits inconveniences to impacted properties while limiting hindrances on access to properties.
- B. Enclose site of the Work with fence adequate to protect the Work against acts of theft, violence, and vandalism. Provide security measures as necessary or as required in the Contract Documents to protect the Work and materials furnished by Contractor. Store materials and construction equipment in a secure area. Lock or disable to prevent use by unauthorized persons during non-working hours.
- C. Enclose temporary offices and storage areas with fence adequate to protect temporary facilities against acts of theft, violence, and vandalism.
- D. When entire or part of site is to be permanently fenced, permanent fence may be built to serve for both permanent and temporary protection of the Work site, provided that damaged or defaced fencing is replaced prior to Substantial Completion.
- E. Protect temporary and permanent openings and close openings in existing fences to prevent intrusion by unauthorized persons. Bear responsibility for protection of plant and material on site of the work when openings in existing fences are not closed.
- F. During night hours, weekends, holidays, and other times when no work is performed at site, provide temporary closures or enlist services of security guards to protect temporary openings. Provide for mobile patrols of the entire Site at least once a day. Inspect Site security measures and document in daily reports. Inspect site security measures at least once on non-working days. Document inspections on next daily report.
- G. Fence temporary openings when openings are no longer necessary.

### **3.2 ACCESS POINTS**

- A. Lock controlled access points, including private property gates, providing entry to Site and maintain a secure key control to prevent unauthorized access.
- B. Close and secure gates and entry points by locking mechanism when not in use.

### **3.3 ACCESS KEYS**

- A. Maintain access keys in a secure location.
- B. Provide non-duplicating type keys.
- C. Provide two of each access key to Owners' Representatives.

**END OF SECTION**

## **SECTION 01 56 39**

### **TEMPORARY TREE AND PLANT PROTECTION**

#### **PART 1 - GENERAL**

##### **1.1 SUMMARY**

- A. Section includes general protection and pruning of existing trees and plants affected by execution of the Work, whether temporary or permanent construction.
- B. The Contract Drawings identify trees to remain as part of the completed Work. When possible, the Contractor will look to preserve trees within the ROW or easement areas. The Contractor shall protect these trees with protective fencing and avoid operations and placing of equipment that could harm trees designated to be protected.
- C. This section fully applies to protection of new landscape Work.
- D. Contractor shall make available a certified arborist to observe, manage tree care, manage pruning, and direct the Contractor on tree protection measures during construction as needed to ensure that impacts to trees are minimized.

##### **1.2 DEFINITIONS**

- A. Caliper: Diameter of a trunk measured by a diameter tape at 6 inches above the ground for trees up to, and including, 4-inch size; and 12 inches above the ground for trees larger than 4-inch size.
- B. Plant Protection Zone: Area surrounding individual trees, groups of trees to be protected as indicated on Contract Drawings.
- C. Tree Protection Zone: Area surrounding individual trees or groups of trees to remain during construction and defined by the drip line of individual trees or the perimeter drip line of groups of trees plus ten feet, unless otherwise indicated.
- D. Vegetation: Trees, shrubs, groundcovers, grass, and other plants.
- E. Arborist: A Consulting Arborist registered with the American Society of Consulting Arborists (ASCA).
- F. Certified Arborist: Certified by The International Society of Arboriculture (ISA).

##### **1.3 SUBMITTALS**

- A. Procedures: Section 00150.
- B. Product Data: For each type of product indicated.
- C. Tree Pruning Schedule: Written schedule detailing scope and extent of tree pruning of trees to remain that interfere with or are affected by construction. Including the following:

1. Species and size of tree.
  2. Location on Site plan. Include unique identifier for each.
  3. Reason for pruning.
  4. Description of pruning to be performed.
  5. Description of maintenance following pruning.
- D. Qualification Data: For qualified arborist and tree service firm.
- E. Certification: From arborist, certifying that trees indicated to remain have been protected during construction according to recognized standards and that trees were promptly and properly treated and repaired when damaged.
- F. Maintenance Recommendations: From arborist, for care and protection of trees affected by construction during and after completing the Work.
- G. Existing Conditions: Documentation of existing trees to remain, which establishes preconstruction conditions that might be misconstrued as damage caused by construction activities.
1. Use sufficiently detailed photographs or videotape.
  2. Include plans and notations to indicate specific wounds and damage conditions of each tree or other plants designated to remain.
  3. Contractor's Consulting Arborist shall accompany Contractor on preconstruction walk to photograph existing conditions per Section 01 32 33.

#### **1.4 QUALITY ASSURANCE**

- A. Arborist Qualifications: An arborist certified by ISA or licensed in the jurisdiction where Project is located.
- B. Tree Pruning Standard: Comply with ANSI A300 (Part 1), "Tree, Shrub, and Other Woody Plant Maintenance--Standard Practices (Pruning)."
1. Before tree protection and trimming operations begin, meet with representatives of authorities having jurisdiction, Owners' Representative, and Owners' contact for public communications to review tree protection and trimming procedures and responsibilities. Trees that are to be protected will be temporarily marked in an agreed upon manner during construction.

#### **1.5 PROJECT CONDITIONS**

- A. The following practices are prohibited within protection zones:
1. Storage of construction materials, debris, or excavated material.
  2. Parking vehicles or equipment.
  3. Frequent foot traffic (i.e. use as a travel corridor, etc.) unless allowed by Arborist.

4. Erection of sheds or structures.
5. Impoundment of water.
6. Excavation or other digging
7. Attachment of signs to or wrapping materials around trees or plants unless otherwise indicated.
8. Solid or liquid waste disposal.
9. Use of tree trunks as a winch support, anchorage, or similar function.
10. Use of herbicides or other that could damage trees.

## **PART 2 - PRODUCTS**

### **2.1 MATERIALS**

- A. Drainage Fill: Selected crushed stone, or crushed or uncrushed gravel, washed, ASTM D448, Size 24, with 90 to 100 percent passing a 2-1/2-inch sieve and not more than 10 percent passing a 3/4-inch sieve.
- B. Topsoil: As specified in Schedule A
- C. Obtain topsoil only from well-drained sites where topsoil is 4 inches deep or more; do not obtain from bogs or marshes.
- D. Organic Mulch: Free from deleterious materials and suitable as a top dressing for trees and shrubs, consisting of one of the following:
  1. Type: Ground or shredded bark.
  2. Size Range: 3 inches maximum, 1/2 inch minimum.
- E. Protection Zone Fencing: Maintain existing tree protection chain link fencing at all times.
- F. Protection Zone Signage: Shop fabricated, rigid plastic or metal sheet with attachment holes pre-punched and reinforced; legibly printed with nonfading lettering and as follows:
  1. Signs shall clearly state: "Warning: Tree Protection Zone" or "Warning: Plant Protection Zone" as appropriate.

## **PART 3 - EXECUTION**

### **3.1 EXAMINATION**

- A. Prepare written report, endorsed by arborist, listing conditions detrimental to tree and plant protection.

### **3.2 PREPARATION**

- A. Locate and clearly identify trees to remain. Flag Tie a 1-inch, blue, vinyl tape around each tree trunk at 54 inches above the ground.

- B. Protect tree root systems from damage caused by runoff or spillage of noxious materials while mixing, placing, or storing construction materials. Protect root systems from ponding, eroding, or excessive wetting caused by dewatering or other operations.
- C. Tree Protection Zones: Mulch areas inside tree protection zones and other areas indicated.
  1. Apply 4-inch average thickness of organic mulch. Do not place mulch within 6 inches of tree trunks.

### **3.3 TREE AND PLANT PROTECTION ZONES**

- A. Protection Zone Fencing: Delineate all protection zones with chain link fence as shown on the Drawings. Maintain existing protection zone fencing along edges of protection zones. Maintain or modify existing fencing so as not to obstruct safe passage or visibility at vehicle intersections where fencing is located adjacent to pedestrian walkways or in close proximity to street intersections, drives, or other vehicular circulation.
  1. Existing Chain-Link Fencing: Modify or adjust as and when necessary to accomplish Work without compromising protection of trees.
  2. Existing Posts: Modify or adjust as and when necessary to accomplish Work without compromising protection of trees.
  3. Existing Access Gates: Modify or adjust as and when necessary to accomplish Work without compromising protection of trees.
- B. Protection Zone Signage: Install protection zone signage in visibly prominent locations in the following manner: Install one sign spaced approximately every 35 feet on protection zone fencing.
- C. Maintain protection zone fencing and signage in good condition and remove when construction operations are complete and equipment has been removed from the Site.
  1. Do not remove protection zone fencing, even temporarily, to allow deliveries or equipment access through the protection zone.
  2. Temporary access into the protection zone perimeter may be permitted for exceptional circumstances, subject to preapproval in writing by the Owners, based upon input from the arborist. Prior to opening any permitted temporary accesses, construct a root buffer effective against soil compaction as directed by the Owners, based upon input from the arborist. Maintain root buffer so long as access is permitted.

### **3.4 EXCAVATION**

- A. For excavation at edge of protection zones, redirect roots in backfill areas where possible. If encountering large, main lateral roots, expose roots beyond excavation limits as required to bend and redirect them without breaking. If encountered immediately adjacent to location of new construction and redirection is not practical, cut roots approximately 3 inches back from new

construction and as required for root pruning. Arborist shall be present during such activities.

- B. Do not allow exposed roots to dry out before placing permanent backfill. Provide temporary earth cover or pack with peat moss and wrap with burlap. Water and maintain in a moist condition. Temporarily support and protect roots from damage until they are permanently relocated and covered with soil.

### **3.5 ROOT PRUNING**

- A. Prune roots that are affected by temporary and permanent construction. Prune roots as follows:
  - 1. Cut roots manually by digging a trench and cutting exposed roots with sharp pruning instruments; do not break, tear, chop, or slant the cuts. Do not use a backhoe or other equipment that rips, tears, or pulls roots.
  - 2. Cut Ends: Coat cut ends of roots more than 1-1/2 inches in diameter with an emulsified asphalt or other coating formulated for use on damaged plant tissues and that is acceptable to arborist.
  - 3. Temporarily support and protect roots from damage until they are permanently redirected and covered with soil.
  - 4. Cover exposed roots with burlap and water regularly per paragraph 3.04.B.
  - 5. Backfill as soon as possible.
- B. Root Pruning at Edge of Protection Zone: Prune roots 12 inches outside of the protection zone, by cleanly cutting all roots to the depth of the required excavation.

### **3.6 CROWN PRUNING**

- A. Prune branches that are affected by temporary and permanent construction. Prune branches as follows:
  - 1. Prune trees to remain to compensate for root loss caused by damaging or cutting root system. Provide subsequent maintenance during Contract period as recommended by arborist.
  - 2. Pruning Standards: Prune trees according to ANSI A300 and the following:
    - a. Type of Pruning: Cleaning, Thinning, Raising, Reduction.
  - 3. Cut branches with sharp pruning instruments; do not break or chop.
  - 4. Do not apply pruning paint to wounds.
- B. Chip removed branches and dispose of offsite.



### **3.7 REGRADING**

- A. Lowering Grade: Where new finish grade is indicated below existing grade around trees, slope grade beyond the protection zone. Maintain existing grades within the protection zone.
- B. Raising Grade: Where new finish grade is indicated above existing grade around trees, slope grade beyond the protection zone. Maintain existing grades within the protection zone.

### **3.8 FIELD QUALITY CONTROL**

- A. Inspections: Engage arborist to direct plant protection measures in the vicinity of trees, shrubs, and other vegetation indicated to remain and to prepare inspection reports.

### **3.9 REPAIR AND REPLACEMENT**

- A. General: Repair or replace trees and vegetation indicated to remain that are incidentally damaged by construction operations, in a manner recommended by arborist and approved by Owners' Representative. Perform repairs within 24 hours.
  - 1. Submit details of proposed root cutting and tree and shrub repairs.
  - 2. Have arborist perform the root cutting, branch pruning, and damage repair of trees and shrubs.
  - 3. Treat damaged trunks, limbs, and roots according to arborist's written instructions.

### **3.10 DISPOSAL OF SURPLUS AND WASTE MATERIALS**

- A. Disposal: Remove excess excavated material, displaced trees, trash and debris, and legally dispose of them offsite.

**END OF SECTION**

## **SECTION 01 57 00**

### **ENVIRONMENTAL CONTROLS**

#### **PART 1 - GENERAL**

##### **1.1 SUMMARY**

- A. The Work specified in this Section includes the requirements for furnishing general environmental management and environmental controls requirements during construction as designated in the Contract Documents.
- B. This Section does not address the management of contaminated media.
- C. Contractor to designate a “qualified person” to monitor all environmental controls on the work site. This qualified person shall have the authority to modify Contractor’s operations to comply with these specifications.

##### **1.2 SUBMITTALS**

- A. Procedures: Section 00150.
- B. Complete and submit the following information prior to the start of mobilization activities:
  - 1. Enforcement of Environmental Controls:
    - a. Name and phone number of person responsible for enforcement of environmental controls (24-hour contact).
  - 2. Site Maintenance Plan:
    - a. Types of construction materials stored on site.
    - b. Location where waste materials are disposed.
    - c. Length of time that waste materials are stored on site before being disposed.
  - 3. Street Cleaning Plan:
    - a. Methods of controlling dust and dirt on streets.
    - b. Methods incorporated to eliminate the transport of mud and dirt onto private or public roads by motor vehicles leaving the site. Methods used may include but are not limited to the following:
      - 1) Construction and maintenance of wheel wash at site egress.
      - 2) Construction of a stabilized pad of rock spalls at site entrances of adequate dimensions to accomplish objective.
      - 3) Periodic addition of rock to stabilized pad to maintain function.
      - 4) Thorough tire washing prior to vehicles exiting site and routing of wash water to containment facility.

- c. Do not allow water used for washing vehicles and equipment to enter storm drains unless sediment, petroleum products, fresh concrete products, or other deleterious materials are separated prior to discharge and applicable permits have been secured.
4. Air Pollution Control Plan to meet the requirements of this Section, including:
  - a. Measures to ensure vehicles and equipment do not emit excessive pollutants to the air.
  - b. Measures to minimize the discharge of smoke, dust, and other contaminants into the atmosphere that violate the regulations of legally constituted authorities.
5. Noise Pollution Control Plan to meet the requirements of this Section.
6. Vibration Control Plan to meet the requirements of this Section.
7. Safety Data Sheets (SDS): Submit SDS to the Owners' Representative for all chemicals, materials, and other products to be utilized in the Work.
8. Spill Prevention and Control Countermeasures Plan (SPCCP) to meet the requirements of this Section.
9. Pollution Control Plan (PCP)
  - a. Develop and submit a PCP to prevent pollution related to Contractor operations for approval 14 days before the preconstruction conference. Maintain a copy of the PCP on-site at all times during construction activities, readily available to employees and inspectors. Ensure that all employees comply with the provisions of the PCP.
  - b. Include the following information in the PCP:
    - 1) Identify a professional on-call spill response team.
    - 2) Identify all Contractor activities, hazardous substances used and wastes generated.
    - 3) Describe how hazardous substances and wastes will be stored, used, contained, monitored, disposed of and documented. Include pollution prevention, spill response, waste reduction, dust prevention, off site tracking prevention, washout facility design, vehicle and equipment fueling and maintenance procedures, employee training and emergency contact information.
    - 4) Include the waste determination results of waste generated onsite. Provide reuse, recycle, and disposal options and the reasons for selecting those alternatives.
    - 5) Include or refer to the SPCCP and the hazardous waste contingency plan, if required.

- 6) Include scaled site plans showing locations for hazardous substance storage, spill response equipment, communications equipment and fire suppression equipment.

## **PART 2 - PRODUCTS (NOT USED)**

## **PART 3 - EXECUTION**

### **3.1 SITE MAINTENANCE**

- A. Keep the work site(s), including staging areas and Contractor's facilities, clean and free from rubbish and debris. Remove materials and equipment from the Site when they are no longer necessary. Upon completion of the Work and before request for inspection, clear the work site of equipment, unused materials, and rubbish to present a clean and neat appearance. Where surfaces have been damaged, replace as if new or per landscaping requirements.
- B. Clean Up:
  1. Do not allow waste material to remain on the site of the work or on adjacent streets. Collect, carry off the site and legally dispose of such materials daily, weekly or as otherwise specified by the Owners' Representative.
  2. Keep facilities clear of refuse, rubbish, and debris that may accumulate.
  3. Handle paints, solvents, and other construction materials with care to prevent entry of contaminants into storm drains, surface waters, or soils.
  4. Washing of concrete container where wastewater may reach adjacent property or natural water courses will not be permitted. Remove any excess concrete to the sanitary landfill.
- C. Street Cleaning:
  1. Prevent dirt and dust from escaping from trucks and equipment departing the work site, by covering dusty loads, washing vehicle tires before leaving the site, using crushed rock at entrances, or other reasonable methods.
  2. When Work involves dump trucks and other equipment on paved streets and roadways, clean, vacuum, and/or use approved sweeper on streets at least twice per day, or as required by the Owners' Representative during each day's operations.
- D. Removal of Materials:
  1. Clean up and remove all refuse, debris, equipment and unused materials of any kind resulting from the Work periodically as the Work progresses, immediately after completion of the Work, and as requested by the Owners' Representative

2. Prior to final acceptance of the Work by the Owners' Representative, remove all equipment and temporary structures, rubbish, and waste, and generally clean up the Site and the premises. Where brush and trees beyond the limits of the project have been disturbed, remove and dispose of or restore same as directed.
  3. Recycle materials per the requirements of ORS Chapter 459A.
- E. Cleaning drains: Clean all drainage facilities such as inlets, catch basins, culverts, and open ditches of all excess material or debris that result from the Work.
- F. Cleaning Paved Surfaces and Appurtenances
1. Clean all pavement surfaces, whether new or existing, within the limits of the Work. Clean existing improvements such as curbs, gutters, walls, sidewalks, and castings, for manholes, monuments, water gates, lamp poles, vaults, signs, and other similar installations.
  2. Flush the street with a pressure type flusher. Hand broom or flush all sidewalks. All flushing shall be in accordance with applicable permits.

### **3.2 AIR POLLUTION CONTROL**

- A. Do not discharge smoke, dust, and other contaminants into the atmosphere that violate permits or the regulations of legally constituted authorities. Do not allow internal combustion engines to idle for prolonged periods of time. Maintain construction vehicles and equipment in good repair. When exhaust emissions are determined to be excessive by the Owners' Representative, repair or replace equipment.
- B. Minimize dust nuisance by cleaning, sweeping, and sprinkling with water, or by other means. The use of water in amounts that result in mud on public or private roads, is not acceptable as a substitute for sweeping or other methods. Make equipment for this operation available at all times.

### **3.3 NOISE CONTROL**

- A. Perform all Work in compliance with the City of Wilsonville Noise Ordinance.
- B. Construction noise is monitored by the Contractor. Owners' Representative, or persons authorized by the Owners may also monitor construction noise. Upon notification by the Owners' Representative that a violation of the Noise Control Code exists or has occurred, use all means necessary to comply with the Noise Compliance Code.
1. Equip all equipment used in the Work with sound control devices no less effective than those provided on the original equipment. Do not use equipment with an unmuffled exhaust.
  2. Use equipment that complies with pertinent standards of the U.S. Environmental Protection Agency.

- C. Provide the following noise abatement equipment or operate construction equipment in the following manner to avoid exceeding noise limitation.
  - 1. Locate noisy portable equipment, such as generators or compressors, as far away from site boundaries as practicable.
  - 2. Construct noise barriers around stationary construction equipment that has to be utilized at locations near the property line and around mobile equipment as necessary or provide suitable and effective noise screening.
  - 3. Shut off idling equipment when not in active use.
  - 4. Vehicles are prohibited from using unmuffled compression brakes.
  - 5. Secure all loose equipment on every vehicle to prevent such equipment from generating noise when the vehicle is in motion. This applies to cargo being transported, tie-down equipment, parts of the vehicle, and any other item anticipated to generate noise during vehicle movement.

### **3.4 VIBRATION CONTROL**

- A. Contractor's means and methods shall limit vibrations that may damage existing utilities and structures.
- B. Owners shall hire a vibration monitoring consultant when required. Vibration monitoring shall be performed when deemed necessary by the Owners' Representative.

### **3.5 EROSION AND SEDIMENT CONTROL**

- A. Comply with all conditions and requirements of Section 01 57 13 Temporary Erosion and Sediment Control.

### **3.6 CHEMICALS AND HAZARDOUS MATERIALS USED ON SITE**

- A. Store and dispose of all hazardous or potentially hazardous chemicals used during the Project construction or furnished for Project operation in accordance with all applicable local, state, and federal laws and regulations and with the (Material) Safety Data Sheets for those chemicals.
- B. Store within a containment area that minimizes contact of the chemicals and storage containers with precipitation, surface flows due to precipitation, or flows from adjacent areas. If precipitation or surface water flows contact the chemicals or the storage containers, notify the Owners' Representative. If spills occur in the containment area, immediately contain and clean up the spill to prevent material from entering storm drains, stream channels, ground water, or from being absorbed by the underlying pavement or soil and immediately notify the Owners' Representative.
- C. Collect waste oil, used oil filters, other waste petroleum materials, and any other hazardous materials at suitable disposal facilities off the jobsite.
- D. Construct on-site temporary fuel storage facilities that comply with all applicable current regulations.
- E. Comply with the requirements of Section 01 35 29 Health and Safety.

### 3.7 OIL SPILL PREVENTION AND CONTROL

- A. Prevent, contain, and clean spilled oil, fuel, and other petroleum products. Do not discharge oil from equipment or facilities into state waters or onto adjacent land.
- B. At a minimum, perform the following measures regarding oil spill prevention, containment and cleanup:
  - 1. Inspect fuel hoses, lubrication equipment, hydraulically operated equipment, oil drums, and other equipment and facilities regularly for drips, leaks, or signs of damage, and maintain and store properly to prevent spills. Maintain proper security to discourage vandalism.
  - 2. Dike or locate all land-based oil and product storage tanks to prevent spills from escaping to the water. Line dikes and subsoils with impervious material to prevent oil from seeping through the ground and dikes.
  - 3. Immediately contain all visible floating oils with booms, dikes, or other appropriate means and remove from the water prior to discharge into state waters. Immediately contain all visible oils on land using dikes, straw bales, or other appropriate means and remove using sand, ground clay, sawdust, or other absorbent material, and properly dispose of waste materials. Temporarily store waste materials in drums or other leak-proof containers after cleanup and during transport to disposal. Dispose of waste materials off jobsite at an approved site.
  - 4. In the event of any oil or product discharges into public waters, or onto land with a potential for entry into public waters; immediately commence response actions to protect human health and the environment. Follow the PCP, SPCC Plan and Contingency Plan, as appropriate. If any of the provisions in these plans conflict, implement the actions providing the greatest protection of public health and safety and the environment. Then inform the Owners. If the quantity released exceeds the state or federal reportable quantities, or if the release impacts or threatens to impact any surface water body, immediately notify DEQ by the Oregon Emergency Response System (OERS) at 1-800-452-0311 and the EPA and U.S. Coast Guard through the National Response Center (NRC) at 1-800-424-8802 (federal reportable quantities or spills impacting or potentially impacting water only). If the quantity released is unknown, proceed with OERS and NRC notifications. Reportable quantities are listed at 40 CFR 302.4 and OAR 340-142-0040 to OAR 340-142-0050.
    - a. Conduct cleanup of the released material according to all applicable laws and DEQ requirements. Clean up to background levels unless otherwise agreed to by the Owners in writing.
    - b. Provide a written report to the Owners' Representative using the DEQ Spill/Release Report form, within 14 days of completing spill response, but no more than 30 days after the initial event. If the spill

was reported to DEQ, submit the report to DEQ concurrently.  
Include a description of how future releases will be prevented.

5. Maintain on the job at each site, and restock as necessary to ensure an adequate and continuous supply, all materials necessary for containment and control.

### **3.8 PROTECTION OF NATURAL RESOURCES**

- A. General: It is intended that the natural resources within the project boundaries and outside the limits of permanent work performed under this Contract be preserved in their existing condition or be restored to an equivalent or improved condition upon completion of the work. Confine construction activities to areas defined by the public roads, easements, and work area limits shown on the Drawings. Return construction areas to their pre-construction elevations except where surface elevations are otherwise noted to be changed.
- B. Land Resources: Do not remove, cut, deface, injure or destroy trees or shrubs outside the work area limits. Do not remove, deface, injure or destroy trees within the work area without permission from the Owners' Representative. See Section 01 56 39 for additional requirements for tree and planting protection.
  1. Repair or Restoration: Repair or replace any trees or other landscape features scarred or damaged by equipment or construction operations as specified below. The repair and/or restoration plan shall be favorably reviewed prior to its initiation.
  2. Temporary Construction: For construction access roads and work areas near waterways and wetlands, use a rock workpad or other measures to minimize soil compaction from heavy equipment. Place a geotextile fabric, chain link fence, or other equally effective material under the temporary rock to protect the existing ground and assist in removal of temporary work pad fill rock. Following construction, remove all of the temporary work pad materials, and regrade and restore the area according to the Drawings. Remove all signs of temporary construction facilities such as haul roads, work areas, structures, foundations of temporary structures, stockpiles of excess or waste materials, or any other vestiges of construction as directed by the Owners' Representative. Level all temporary roads, parking areas and any other areas that have become compacted or shaped. Any unpaved areas where vehicles are operated shall receive a suitable surface treatment or shall be periodically wetted down to prevent construction operations from producing dust damage and nuisance to persons and property, at no additional cost to the Owners. Keep haul roads clear at all times of any object that creates an unsafe condition. Promptly remove any contaminants or construction material dropped from construction vehicles. Do not drop mud and debris from construction equipment on public streets. Sweep clean turning areas and pavement entrances as necessary.
- C. Cultural Resources Preservation: The Contractor's attention is directed to the National Historic Preservation Act of 1966 (16 U.S.C 470) and 36 CRF 800



which provides for the preservation of potential historical architectural, archeological, or cultural resources (hereinafter called "cultural resources"). The project site has been identified as a potential cultural resource site. The site has an Inadvertent Discovery Plan for Cultural Resources, which is attached to this section for Contractor reference. If any cultural resources or human remains are encountered during construction, all construction activity within a 100-foot radius of the initial discovery must immediately cease and the resource protected from further disturbance. Immediately contact the Owners. Contractor shall follow the Inadvertent Discovery Plan if cultural materials including human remains are encountered during construction.

- D. Water Resources: Investigate and comply with all applicable federal, state and local regulations concerning the discharge (directly or indirectly) of pollutants to the underground and natural waters. Perform all work under this Contract in such a manner that any adverse environmental impacts are reduced to a level that is acceptable to the Owners and regulatory agencies. Refer to Specification Section 31 23 19 Dewatering, for "dewatering" water disposal requirements.
1. Oily Substances: At all times, special measures shall be taken to prevent oily or other hazardous substances from entering the ground, drainage areas or local bodies of water in such quantities as to affect normal use, aesthetics or produce a measurable impact upon the area. Any soil or water that is contaminated with oily substances due to the Contractor's operations shall be disposed of in accordance with applicable regulations.
  2. Submit a plan to control water pollution effectively during construction of the Work. Such program shall show the schedule for the erosion control work included in the Contract and for all water pollution control measures, which the Contractor proposes to take in connection with construction of the project to minimize the effects of his operations upon adjacent streams and other bodies of water. The Contractor shall not perform any clearing and grubbing or earthwork on the project, other than that specifically authorized in writing by the Owners' Representative, until such plan has been accepted. The Owners will not be liable to the Contractor for failure to accept all or any portion of an originally submitted or revised water pollution control plan, nor for any delays to the work due to the Contractor's failure to submit an acceptable water pollution control plan. The Contractor may request the Engineer to waive the requirement for submission of a written plan for control of water pollution when the nature of the Contractor's operation is such that erosion is not likely to occur. Waiver of this requirement will not relieve the Contractor from responsibility for compliance with the other provisions of this Section. Waiver of the requirement for a written plan for control of water pollution will not preclude requiring submittal of a written plan at a later time if the Owners' Representative deems it necessary because of the effect of the Contractor's operations.
  3. If the measures being taken by the Contractor are inadequate to control water pollution effectively, the Engineer may direct the Contractor to revise his operations and his water pollution control program. Such directions will be

in writing and will specify the items of work for which the Contractor's water pollution control measures are inadequate. No further work shall be performed on said items until the water pollution control measures are adequate; and if also required, a revised water pollution control plan has been accepted.

4. Where erosion which will cause water pollution is probable due to the nature of the material or the season of the year, the Contractor's operations shall be so scheduled that permanent erosion control features will be installed concurrently with or immediately following grading operations.
5. Nothing in the terms of the Contract nor in the provisions in this Section shall relieve the Contractor of the responsibility for compliance with applicable statutes relating to prevention or abatement of water pollution.
6. The Contractor shall also conform to the following provisions:
  - a. Do not discharge contaminated or sediment-laden water, including drilling fluids and waste, or water contained within a work area isolation, directly into any waters of the State or U.S. until it has been satisfactorily treated (for example: bioswale, filter, settlement pond, pumping to vegetated upland location, bio-bags, dirt bags). Test and record turbidity of water to be discharged before discharging to a receiving stream; re-test and record turbidity whenever activities affecting discharge change, or as needed to comply with permits. Treatment shall meet the turbidity requirements below.
  - b. Do not cause turbidity in waters of the State or U.S. greater than 10% above background reading (up to 100 feet upstream of the Project), as measured 100 feet downstream of the Project.
  - c. During construction, monitor in-stream turbidity in waters of the State or U.S., and inspect all erosion controls daily during the rainy season and weekly during the dry season, or more often as necessary, to ensure the erosion controls are working adequately meeting treatment requirements.
  - d. If monitoring or inspection shows that the erosion and sediment controls are ineffective, mobilize work crews immediately to make repairs, install replacements, or install additional controls as necessary.
  - e. Underwater blasting is not allowed.
  - f. Implement containment measures adequate to prevent pollutants or construction and demolition materials, such as waste spoils, fuel or petroleum products, concrete cured less than 24 hours, concrete cure water, silt, welding slag and grindings, concrete saw cutting byproducts and sandblasting abrasives, from entering waters of the state or U.S.
  - g. Cease project operations under high flow conditions that may result in inundation of the project area, except for efforts to avoid or minimize resource damage.

- h. The Owners' Representative retains the authority to temporarily halt or modify the Project in case of excessive turbidity or damage to natural resources
- i. Where working areas encroach on live streams, barriers adequate to prevent the flow of muddy water into streams shall be constructed and maintained between working areas and streams.
- j. Where applicable, See Section 01 57 19 Temporary Water Management for work within flowing streams.
- k. Mechanized equipment shall not be operated in wetted channels of live streams, unless the work to be performed using such equipment is isolated from the wetted channel.
- l. Water containing mud or silt from aggregate washing or other operations shall be treated by filtration, or retention in a settling pond, or ponds, adequate to prevent muddy water from entering live streams.
- m. When operations are completed, return to pre-construction conditions. See Surface Restoration Drawings.
- n. Chlorinated Water: Take special measures to prevent chlorinated water from entering the ground or surface waters. Dechlorinate chlorinated water prior to discharge. If the distance from the discharge point to a regulated receiving stream is less than 1,000 feet and the regulated receiving stream has a flow rate of less than 50 cfs, dechlorinate or collect and hold water in a detention facility until testing confirms chlorine concentrations are 0.1 mg/l total residual chlorine or less. Test and record chlorine concentrations before discharging to a receiving stream; re-test and record chlorine whenever activities affecting discharge change, or as needed to comply with permits.
- o. Extreme pH: Take special measures to prevent water with extreme pH values from entering the ground or surface waters. For discharge to regulated receiving streams, test pH prior to discharge and treat as needed to maintain values between 6.5 and 8.5. Re-test and record pH levels whenever activities affecting discharge change, or as needed to comply with permits.
- p. Discharge rates shall not exceed the bankfull flow rate for the receiving channel, in order to prevent soil or channel erosion. Temporary best management practices (BMPs) may also be applied to control downstream effects during regular maintenance or emergency drainage.

### **3.9 PROTECTION OF FISH AND WILDLIFE AND THEIR HABITAT**

#### **A. Migratory Birds**

- 1. Comply with the Migratory Bird Treaty Act (16 U.S.C. 703-712), which protects most species of birds in Oregon and prohibits the removal of nests containing eggs and dependent young. Migratory birds include most birds in Oregon, except pigeons, house sparrows, and starlings. Except where

allowed by the Contract and by permit, do not disturb a migratory bird nest containing eggs or dependent young, or the surface the nest is built on.

2. If migratory bird nests are encountered that contain eggs or dependent young, stop all actions that may disrupt the nest and contact the Owners' Representative. Do not resume Work that may disrupt nesting until approved by the Engineer.
3. Bird management activities necessary to comply with the Migratory Bird Treaty Act (16 U.S.C. 703 712) shall be provided by the Owners. Ensure that the Owners and its permitted agents have access to the project area, including existing work platforms needed to prevent migratory bird nesting. Compliance measures may include, but are not limited to, daily bird harassment, installation and maintenance of devices that discourage nesting birds, and nest removal.
4. Contractor shall perform brush clearing and tree removal for work occurring between March 1 and September 1, 2020 in accordance with Section 01 31 30 Schedule and Construction Constraints.
5. Notify the Owners, in writing, a minimum of 10 days prior to starting activities that could harm nesting birds. Avoid disturbing migratory bird nesting habitat (shrubs, trees, and structures) from March 1 to September 1 of each year. If avoidance is not possible, obtain approval from the Owners before falling trees or clearing vegetation that could disturb migratory bird nesting habitat between March 1 and September 1.
6. Contractor to submit a Tree Removal Plan in accordance with Section 31 10 00 Site Clearing that describes coordination with Owners.

**B. Protection of Wildlife and Wildlife Habitat**

1. Wildlife Removal: The Owners' qualified biologist or ODFW biologists will remove non-game wildlife and aquatic life from wetlands and waterways. Allow biologist access into the wetland or waterway prior to vegetation clearing or ground disturbing activities. Notify the Owners 10 days prior to beginning work in wetlands or waterways.

**END OF SECTION**

This page intentionally left blank.

## **SECTION 01 57 13**

### **TEMPORARY EROSION AND SEDIMENT CONTROL**

#### **PART 1 - GENERAL**

##### **1.1 SUMMARY**

- A. The Contractor shall furnish all materials and labor to comply with the Temporary Erosion and Sediment Control requirements included in the Drawings and respective regulatory erosion control permits.

##### **1.2 REFERENCE SPECIFICATIONS, CODES, AND STANDARDS**

- A. The Contractor shall comply with regulatory permits, specifications, codes, and standards that may include, but not limited to, the following.
  - 1. DEQ 1200-C permit.
  - 2. Contract Document Erosion and Sediment Control Drawings.
  - 3. City of Wilsonville Stormwater and Surface Water
  - 4. Comply with requirements of Section 01 57 00 Environmental Controls

##### **1.3 EROSION AND SEDIMENT CONTROL MANAGER**

- A. Designate and provide a representative as the Erosion and Sediment Control Manager (ESCM) who meets the minimum qualifications:
  - 1. Experience in all major disciplines of public infrastructure construction.
  - 2. Knowledge in principles of and practice of erosion and sediment controls.
  - 3. Skilled in assessing site conditions and effectiveness of erosion control Best Management Practices (BMP) used.
  - 4. Successful completion of erosion control formal training acceptable to the Owners' Representative.

##### **1.4 SUBMITTALS**

- A. Procedures: Section 00150.
- B. The Contractor, at a minimum, shall submit information regarding the following items for approval by the Owners.
  - 1. Materials necessary to comply with ESC and any qualified products lists of local jurisdiction
  - 2. ESC contingency items for emergency response.
  - 3. Sample of proposed Erosion Control Inspection Report Form.
  - 4. Provide the ESCM name, description of experience and training, qualifying certifications, and 24-hr contact phone number no later than the Preconstruction meeting.

5. Schedule of ESC implementation including dates of installation, inspection frequency, rain-related inspection plan, seeding, and removal of all ESC materials at Contract completion.
6. Meet submittal requirements of the City of Wilsonville ESC program.

## **PART 2 - PRODUCTS**

### **2.1 GENERAL**

- A. All products shall comply with the standards and permits listed in Part 1.

## **PART 3 - EXECUTION**

### **3.1 GENERAL**

- A. Contractor shall install and maintain erosion/sedimentation control during construction (any time of year) per the Erosion and Sediment Control (ESC) plan.
- B. The implementation of the ESC plans and the construction, maintenance, replacement, and upgrading of these ESC facilities is the responsibility of the Contractor until all construction is completed and approved and vegetation/landscaping is established.
- C. The erosion control facilities shown on the plans must be constructed in conjunction with all clearing and grading activities, and in such a manner as to ensure that sediment and sediment-laden water do not enter the drainage system, roadways, or violate applicable water standards.
- D. The erosion control facilities shown on the plans are the minimum requirements for anticipated site conditions. During the Project construction period, the ESC facilities shall be upgraded as needed for unexpected storm events and to ensure that sediment and sediment-laden water do not leave the Site.
- E. The erosion control facilities shall be inspected daily by the Contractor and maintained as necessary to ensure their continued functionality.
- F. The erosion control facilities on inactive Sites shall be inspected and maintained a minimum of every two weeks and within 24 hours following a storm event (½ inch or more of rainfall) including weekends and holidays.
- G. General ESC Materials Maintenance, refer to permits and Drawings, where applicable.
  1. Contractor shall remove accumulated sediment and broken-down biofilter bags that restrict performance of catch basins. All catch basins and conveyance lines shall be cleaned prior to paving. The cleaning operation shall not flush sediment-laden water into the downstream system.
  2. Stabilized construction entrances shall be installed at the beginning of construction and maintained for the duration of the Project. Additional

measures may be required to ensure that all paved areas are kept clean for the duration of the Project. See Drawings for temporary gravel construction entrance details.

- H. Filter fabric inlet barriers shall be installed at new and existing storm inlets to prevent sediment and sediment-laden water from entering the storm drainage system.
- I. Contractor shall provide dust control as required to prevent airborne particles from leaving the Site.
- J. Pavement surfaces and vegetation are to be placed as soon as possible.
- K. Seeding shall be performed no later than September 1 for each phase of construction.
- L. If there are exposed soils or soils not fully stabilized from October 31 through March 1, wet weather erosion control measures will be in effect. Exposed soil shall be covered with straw, hydromulch, or plastic sheeting.
- M. Erosion control measures shall be removed by the Contractor when vegetation is fully established.
- N. The Contractor shall notify the Owners' Representative in writing of the location where spoils will be temporarily stored or disposed. A written and signed letter from the property owner where the spoils are stored or disposed shall be provided to the Owners' Representative for approval. The letter shall indicate that the property owner has granted permission to the Contractor for storage or disposal of spoils. The Contractor shall provide erosion control measures at the spoils storage site. The Contractor shall provide to the Owners, for approval, a plan for hauling spoils. The plan shall show the route and how the Contractor intends to prevent sediment from being deposited along the route.
- O. The Contractor shall provide erosion control along all access roads used for construction. The construction access roads shall be maintained during construction. Maintenance shall include re-grading as required and placing additional crushed rock surfacing as required. Water bars shall be constructed on access roads where needed to reduce sediment flow on roads.
- P. The Contractor shall prevent sediment from being deposited on any paved roads near the construction Site. A truck wheel washing operation as approved by the Owners' Representative may be required.

### 3.2 TURBIDITY MONITORING

- A. For discharge to regulated work areas (area at or below the ordinary high water (OHW) as shown on the drawings), the Contractor shall implement all reasonably available technological controls and management practices to meet the standard DEQ Water Quality Control (WQC) rule of maintaining no more than a 10 percent increase in project-caused turbidity above background levels.
  - 1. Monitoring and Compliance Requirements:



- a. The Contractor shall observe and record, in a daily log, the color and turbidity or clarity at locations where surface waters from the construction site enter the regulated receiving stream. Describe in the report any apparent differences in color and the clarity of the discharge, and any observable difference in comparison with the receiving stream. If a permit noncompliance or serious water quality issues occur, verbally report to the Owners or Owners' Representative within 24 hours and submit a written report within 5 Calendar Days.
  - b. The Contractor shall monitor and record, in a daily log, turbidity levels within the receiving water each day when working in regulated work areas; compare turbidity caused by authorized actions to background levels; and adapt activities to minimize project-caused turbidity. Required monitoring steps include:
    - 1) Use a turbidity meter that has been calibrated to meet manufacturer requirements.
    - 2) Before beginning work, take in stream turbidity readings approximately 100 feet upstream and downstream of the in-water work area.
    - 3) Take in stream turbidity readings upstream and downstream at two hour intervals or more frequently and perform in-water work based on turbidity measurements according to the following:
      - a) If the downstream reading at the compliance distance is 0 to 4 nephelometric turbidity units (NTU) above upstream levels, continue to work.
      - b) If the downstream reading at the compliance distance is 5 to 29 NTU above upstream levels, work may continue for a maximum of four hours. If turbidity remains 5-29 NTUs above background, stop work and modify work procedures and best management practices (BMP). Resume in water work activities when NTU is 0-5 above background.
      - c) If the downstream reading at the compliance distance is 30 to 49 NTU above upstream levels, work may continue for a maximum of two hours. If turbidity remains 30-49 NTU above background, stop work and modify work procedures and BMP. Resume in water work activities when NTU is 0-5 above background.
      - d) If the downstream reading at the compliance distance is 50 NTU or more above upstream levels, stop all in water work immediately and notify Owners. Owners or Owners' Representative will inform DEQ. Resume in water work activities the next morning.
  - c. Note whether sheen and floating matter are present or absent.
2. Turbidity Control Measures:

The Contractor shall implement all reasonably available controls and practices to minimize turbidity during work which may include, but are not limited to:

- a) Schedule, sequence or phase work activities accordingly.
- b) Install and maintain containment measures for work areas.
- c) Limit the number and locations of crossing events with flowing surface water.
- d) Isolate excavated, disturbed and stockpiled material for edge of flowing surface water.
- e) Apply other effective turbidity control techniques, such as those throughout DEQ's Oregon Sediment and Erosion Control Manual.

3. Reporting:

- a) Record all turbidity monitoring in daily logs that include calibration documentation; background NTUs; compliance point NTUs; comparison of the points in NTUs; location; date; and time for each reading.
- b) Prepare a narrative discussing all exceedances with subsequent monitoring, actions taken, and the effectiveness of the actions.
- c) Retain copies of daily logs for turbidity monitoring on-site and make available to DEQ, USACE, NMFS, USFWS, and ODFW upon request.

**END OF SECTION**

This page intentionally left blank.

## **SECTION 31 09 00**

### **INSTRUMENTATION AND MONITORING**

#### **PART 1 - GENERAL**

##### **1.1 SUMMARY**

- A. The Work covered in this Section consists of providing, installing, monitoring, maintaining, and removing instrumentation required to monitor ground and utility movements in the vicinity of the jacking and reception shafts and along the trenchless alignment for the SW Day Road trenchless crossing at locations specified on the Drawings and herein.
- B. The objective of the instrumentation and monitoring is to verify that construction activities related to the trenchless crossing do not adversely impact existing structures.

##### **1.2 DEFINITIONS**

- A. Action Trigger Level: Level at which corrective actions are required, including procedural modifications that permit excavation to continue without exceeding the specified Maximum Allowable Movement.
- B. Maximum Allowable Movement: Level at which no further movement will be acceptable and if reached requires work to be halted until the acceptance of a plan detailing corrective actions and restorative measures.
- C. Settlement Monitoring Points: Instruments used to measure vertical movement (settlement or heave) at or near the ground surface using optical surveying methods.
- D. Survey Control: A system of precise field measurements of the types and kinds specified herein, utilizing suitable methods and equipment for determination of elevations, coordinates, and distances for performing monitoring point readings.
- E. Utility Monitoring Point: A system for monitoring vertical movement (settlement or heave) of an existing above ground or subsurface utility.

##### **1.3 QUALITY CONTROL**

- A. Calibrate all sensors and readout instruments at the manufacturer's facility prior to shipment.
- B. Provide certification to indicate that the manufacturer's test equipment is calibrated and maintained in accordance with the test equipment manufacturer's calibration requirements, and that all calibrations have been made with equipment certified as meeting standards established by the National Bureau of Standards for that purpose.
- C. Qualifications:

1. Perform survey for location and elevation of utility monitoring points and settlement monitoring points using qualified technicians with previous experience performing the type of survey required. Use a Professional Land Surveyor, registered in the State of Oregon, and with a minimum of 3 years similar surveying experience, to supervise and direct the survey.
2. Perform installation of instruments using qualified technicians with a minimum of 3 years experience and previous experience in the installation of the type of instruments specified herein.

#### 1.4 SUBMITTALS

- A. Qualifications: Provide documentation of surveyor and technicians installing instrumentation qualifications that meets the requirements of paragraph 1.3.C.
- B. Procedures: Submit the following at least 30 calendar days before starting the Work specified in this Section:
  1. Settlement Monitoring Plan: Provide details regarding the Contractor's plan to monitor ground movements as required in the vicinity of the jacking and receiving shafts and for the trenchless crossing. At a minimum, include the following:
    - a. Schedule and outline of procedures and timing for installation and performance of monitoring.
    - b. Detailed plan of proposed monitoring point locations.
    - c. Details regarding all materials that will be used.
    - d. Sample data tables, including information describing the current construction activities (i.e. shaft excavation depths) for each set of monitoring data. Refer to paragraph 3.5 for monitoring schedule.
    - e. Means of coordinating access to any monitoring points outside of the Contractor's work area and control.
  2. Corrective Action Plan: Provide a detailed list of potential immediate and other actions the Contractor may employ, after approval by the Owner's Representative, if Action Trigger Level and Maximum Allowable Movement are reached. The Corrective Action Plan shall anticipate potential sources of ground movements caused by the Work (including both shaft and trenchless construction) and provide a number of feasible alternatives for stopping ground movements and/or restoring the structures to their original condition. The Corrective Action Plan, once approved by the Owner's Representative, will be the only source of pre-accepted actions that the Contractor may employ should monitored points exceed Action Trigger Levels and Maximum Allowable Movement and the Work is stopped without additional approval.
- C. As-built Records: Within 72 hours of installation, provide as-built drawings identifying the actual locations of each instrument, including elevations and coordinates.

- D. **Monitoring Data:** Provide updated monitoring data to the Owner's Representative via paper copies and/or the latest version of Microsoft Excel within 12 hours after each set of readings is taken per the monitoring schedule provided herein.

## 1.5 QUALITY CONTROL

- A. **Survey Methods:** Use closed loop differential leveling methods with a digital level, following the procedures outlined in the latest version of the ODOT "Construction Surveying Manual for Contractors."
- B. **Survey Tolerance:**
1. Install instrumentation within 12 inches of the theoretical location specified or indicated to avoid obstacles or utilities, except where otherwise approved by the Owners' Representative.
  2. The tolerance for monitoring point measurement shall be plus or minus 0.01 foot.
- C. Allowable movement and trigger levels are summarized in the table below.

Feature	Action Trigger Level	Maximum Allowable Movement
Existing Utilities	Vertical: 0.5" (0.04')	Vertical: 1.0" (0.08')
Ground Surface/Roadways	Vertical: 0.5" (0.04')	Vertical: 1.0" (0.08')

## 1.6 CONTRACTOR FURNISHED POINTS AND INDICATORS

- A. The monitoring points described in this Section and as shown on the Drawings, delineate the minimum required monitoring points and systems. The Contractor, at its own cost, may install and monitor additional monitoring points or indicators at locations other than those specified herein upon approval from the Owner's Representative. Inform the Owner's Representative in writing of the description and proposed locations of such additional monitoring points/indicators. Make all additional monitoring point data available to the Owner's Representative for evaluation.

## 1.7 AVAILABILITY OF DATA

- A. Perform all data collection and monitoring point readings and submit to the Owner's Representative each day within 24 hours of the end of work shift. Do not disclose data reports or any other unprocessed data, readings, and observations to third parties outside of the Contract without the express written permission of the Owner's Representative. In the event of noted abnormal monitoring data or in the event of construction-induced damage, increase the frequency of data collection, install additional monitoring points, or provide additional monitoring at no additional cost to the Owner.

## **PART 2 - PRODUCTS**

### **2.1 GENERAL**

- A. Ensure that all instrumentation as shown on the Drawings for a specific element of Work is on site and approved by the Owner's Representative before start of Work for that element.
- B. Upon delivery, check all instrumentation components for completeness and damage. When determined correct and undamaged, deliver all components not to be installed at the Project site to the Owner's Representative.
- C. Provide the monitoring data in an Excel spreadsheet with monitoring points as column headers and each day's measurement as rows. Contractor to coordinate monitoring data transfer with Owner's Representative.

### **2.2 SETTLEMENT MONITORING POINT**

- A. As shown on the Drawings or as approved by the Owner's Representative.

### **2.3 UTILITY MONITORING POINTS**

- A. As shown on the Drawings and as follows, or as approved by the Owner's Representative.
  - 1. Use black steel pipe and threaded couplings, ASTM A53, welded, standard weight, for outer casing.
  - 2. Use FRP or stainless steel rod for inner bench mark monitoring rod.
  - 3. Use oakum or other approved filler for placement between the inner benchmark and outer casing that is suitable for use in settlement markers to prevent migration of debris between benchmark and outer casing.
  - 4. Provide traffic-rated steel monument box with cover at each installation location.

### **2.4 TRAFFIC RATED STEEL MONUMENTS**

- A. Furnish 8-inch ID traffic rated monuments with access cover and install at the ground surface to protect installed instrumentation.
- B. Use steel of sufficient strength to withstand HS-20 traffic loading.
- C. Provide a watertight access cover.

## **PART 3 - EXECUTION**

### **3.1 GENERAL**

- A. Install instrumentation at the locations indicated unless otherwise directed by the Owner's Representative. The monitoring points must be protected from disturbance due to construction activities and vehicular traffic. Install in accordance with the manufacturer's printed instructions and as specified in this Section. Install within the accuracy limits specified by the manufacturer.

### 3.2 SETTLEMENT MONITORING POINTS

- A. Install settlement monitoring points as shown on the Drawings or as approved by the Owner's Representative.

### 3.3 UTILITY MONITORING POINTS

- A. Install utility monitoring points as shown on the Drawings and as follows, or as approved by the Owner's Representative.
1. Notify and obtain utility owner approval prior to installing utility monitoring point.
  2. Utility monitoring point shall be installed by vacuuming a hole above the buried utility to be monitored.
  3. Utility shall be cleaned in the area of the elevation rod installation.
  4. Casing shall be centered over the rod using centralizers.
  5. Casing shall be cut to form a tight fit over the utility.
  6. Ensure installation of monitoring point does not damage the pipe coating.
  7. Backfill around the casing shall be with the removed material.
  8. Provide traffic rated, flush mount, monument box as specified herein at each installation.
  9. Presence of a representative from gas, electrical, and water utilities shall be on site during installation of instrumentation if required by utility owner.

### 3.4 TRAFFIC RATED MONUMENT BOX WITH ACCESS COVER

- A. Set monuments in place with either a bituminous or concrete patching material with 2-inch annular thickness around the monument.
- B. Inside each monument, install a hardened domed head nail embedded into concrete to serve as a leveling point.
- C. Grout monuments in place and paint with a bright orange paint. In areas where instrumentation is subject to damage by construction operation, install suitable barriers or guard posts as necessary to protect the monuments.

### 3.5 MONITORING SCHEDULE

- A. Monitor Instrumentation according to the frequency shown in the table below.

Distance (feet)	Settlement Monitoring Points	Utility Monitoring Points
-100 to 0	each shift	each shift
0 to +100	each shift	each shift



+100 to +200	twice weekly	twice weekly
>+200	monthly	monthly

Distance measured along longitudinal plan tunnel centerline

-100 denotes 100 ft ahead of the tunnel face

+200 denotes 200 ft behind the excavated tunnel face.

- B. Monitor Settlement Monitoring Points and Utility Monitoring Points at least once a week for a minimum of two weeks following completion of the casing installation prior to removal.
- C. Instrumentation will be monitored more frequently if the measurements detect significant, anomalous, or suddenly changing deformations.
- D. Demonstrate functionality of instrument installation by means of one set of readings.
- E. Take baseline readings five days following the instrument installation. When two sets of readings taken one day apart indicate consistent readings within the limits of the instrument accuracy, tunnel excavation within 200 feet and pipeline excavation within 50 feet of the instrument location can proceed, and shaft excavation can start.
- F. Submit an action plan should the installed instrumentation not demonstrate consistent baseline readings.
- G. Coordinate instrumentation monitoring activities with ongoing work. Make probes, sensors, and readout devices available as required.
- H. Temporarily cease activities that create hazards to instrument monitoring or surveying personnel.
- I. Be available to discuss the interpretation of instrumentation data as used in evaluating tunneling and shaft excavation performance and controlling settlements to prevent damage to structures, facilities and utilities.
- J. Provide all corrective measures, modifications, or instrument replacements.

### 3.6 CORRECTIVE ACTIONS

- A. Should verified measurements of any monitoring point indicate that deflections exceed the Action Trigger Levels specified herein, the Contractor shall determine its preferred Correction Action and implement immediately.
- B. Should verified measurements of any monitoring point indicate that deflections exceed the Maximum Allowable Movement, all project work associated with shaft construction and trenchless installation shall stop. The Contractor shall determine its preferred Corrective Action and immediately discuss its proposed plan with, and receive approval confirmation from the Owner's Representative. The Owner's Representative may choose to allow and/or require immediate implementation of specific preapproved corrective action as detailed in the Corrective Action Plan submitted previously by the Contractor.

- C. After implementing the approved corrective action, the Contractor shall verify success of the corrective action by completing additional surveys of the monitoring points. If the verification surveys indicate that the corrective action was not successful or if measurements show increased deflection, then the Contractor shall cease all related operations contributing to the movements, if not already ceased. Submit a revised Corrective Action Plan to resolve the ground movements. Repeat the above process until results are to the satisfaction of the Owner's Representative.
- D. Work shall not recommence until results acceptable to the Owner's Representative have been achieved. This may include, at the discretion of the Owner's Representative, restoring the deflected element(s) to their original position, demonstrating that deflections have been controlled and are not progressing, and modifying construction methods to avoid further unacceptable deflections.
- E. If the Contractor's corrective actions fail to maintain deflections within the Maximum Allowable Movement, then the Owner's Representative reserves the right to stop Work, or maintain Work stoppages, at no additional cost to the Owner until the Contractor implements adequate control measures to the satisfaction of the Owner's Representative. For prolonged Work stoppages, the Owner's Representative may direct the Contractor to stabilize temporary conditions by backfilling, shotcreting, supplementary ground support or improvement, or other means. This may also include other emergency methods to protect adjacent property. The Contractor shall be responsible for all related costs and delays associated with Work stoppages due to exceeding the Maximum Allowable Movement specified herein.

### **3.7 PROTECTION AND MAINTENANCE**

- A. Protect and maintain instruments throughout the duration of monitoring.
- B. Provide protective barriers or protection around instruments in construction areas that are suitable for protecting instruments from damage due to construction activities.
- C. Repair or replace damaged or missing instrument components or entire instruments as required within 24 hours of detection of damage, or as directed by the Owner's Representative. Repair damage to any instrument at no additional cost to the Owner.

### **3.8 REMOVAL OF INSTRUMENTS**

- A. Prior to Final Completion of the Work and at such times as approved by the Owner's Representative, remove the instrumentation installations. Backfill holes and restore surfaces to be even with the surrounding surfaces. Patch and clean the surface to present an appearance equal to the surrounding surface as required by the permitting agency.

## **END OF SECTION**



*This page intentionally left blank.*

This page intentionally left blank.

## **SECTION 31 41 00**

### **SHAFT EXCAVATION AND SUPPORT**

#### **PART 1 - GENERAL**

##### **1.1 SUMMARY**

- A. The Work specified in this Section includes minimum requirements for the support of excavations for the jacking and receiving shafts located for the SW Day Road trenchless crossing.
- B. Design, furnish, install, and maintain a system of supports, including all bracing, ground stabilization or treatment, and associated items, to retain shaft excavation in a safe manner, to control ground movements, and to prevent damage to adjacent utilities and facilities. Upon completion of the required construction, remove the support system and backfill the shaft excavations, as specified herein.
- C. The American Iron and Steel Provisions apply to this project. Any iron or steel (e.g., steel sheet piles and supports) that the Contractor plans to permanently leave in place after construction must comply with the American Iron and Steel Provisions. Refer to Section 01 11 00, Summary of Work.

##### **1.2 REFERENCES**

- A. American Association of State Highway and Transportation Officials (AASHTO)
  - 1. M-133(86) – Preservatives and Pressure Treatment Process for Timber
- B. American Concrete Institute (ACI)
  - 1. 318 - Building Code Requirements for Reinforced Concrete
- C. American Institute of Steel Construction (AISC)
  - 1. Manual of Steel Construction
- D. American National Standards Institute/American Welding Society (ANSI/AWS)
  - 1. D1.1 - Structural Welding Code - Steel
- E. American Society for Testing and Materials (ASTM)
  - 1. A36 – Standard Specification for Carbon (SSF) Structural Steel
  - 2. A328 – SSF Steel Sheet Piling
- F. International Building Code (IBC)
- G. Oregon Standard Specifications for Construction (OSSC)
  - 1. Section 00540 – Structural Concrete.
- H. West Coast Lumber Inspection Bureau (WCLIB)

1. Grading Rules
- I. Western Wood Products Association (WWPA)
  1. Grading Rules

### **1.3 SUBMITTALS**

- A. Provide the name and qualifications of the shaft excavation and support contractor and shaft excavation and support superintendent responsible for constructing the excavation support system. Include a list of past excavation support design projects during the past 5 years showing: date of work, location, project name, owner, and type of excavation system used. Experience requirements are included in paragraph 1.4.
- B. Provide the name and qualifications of the excavation support system designer responsible for the shaft excavation support system design. Include a list of past excavation support design projects during the past 5 years showing: date of work, location, project name, owner, and type of excavation support system used. Experience requirements are included in paragraph 1.4.
- C. Construction method to be used for the installation of each system.
- D. Working drawings indicating means and methods of excavation and support at each shaft. Include, as a minimum, the sequence of operations, equipment to be used, and arrangements of supports. Indicate sizes, shapes, material specifications, and elevations, as related to the depth of excavation at intermediate stages of construction.
- E. Calculations for excavation support systems. Calculations shall include estimates of likely deflections, deformations or settlement of the support system and maximum tolerable values. Provide calculations for jacking shafts, applying the jacking loads to the thrust restraint system, and indicate resulting stresses and deflections applied to the shaft. Calculations shall be sealed by a Professional Engineer registered in the State of Oregon.
- F. Shop drawings showing dimensions and elevation, and structural details for each excavation support system utilized at each shaft. Include on the drawings any required construction sequence, preloading, testing, monitoring, and rebracing/removal requirements. Shop drawings shall be prepared and sealed by a Professional Engineer registered in the State of Oregon.
- G. Provide American Iron and Steel (AIS) step certification letter(s) for any iron or steel that the Contractor plans to permanently leave in place after construction.
- H. Site drainage and groundwater control details for each shaft. Provide a description of the means and methods that will be used to control groundwater during the shaft excavation process. See Section 31 23 19, Dewatering for dewatering requirements.
- I. Excavation subgrade treatment details for each shaft, including details of working slab, subdrains, and sump construction.

- J. Break-in/Breakout plans for each shaft indicating support installed and ground stabilization or treatment measures implemented to maintain excavation support and stability when breaking in or out of jacking (entry) pit and into receiving (exit) pit. Provide details of launching seals, and ground improvement provisions where applicable.
- K. Quality Control Procedures:
  - 1. Materials testing requirements and results.
  - 2. Deflection monitoring requirements and results.
- L. Submit a schedule showing the sequence and duration of activities for shaft excavation, support, and groundwater control measures.
- M. Submit a contingency plan for alternative or supplementary procedures to be implemented if excavation support system performs unsatisfactorily or if groundwater control measures are inadequate.
- N. A Settlement Control Plan to protect existing facilities, utilities, structures, streets, newly installed pipeline, and other improvements from damage due to settlement resulting from excavation and support. Include specific methods and procedures to be used to minimize ground loss. Include procedures for monitoring for loss of ground, ground control procedures, and grouting plans.
- O. Materials:
  - 1. Granular Shaft Backfill – Submit product data meeting the requirements of Section 31 23 00, Earthwork.

#### **1.4 QUALITY CONTROL**

- A. The shaft excavation and support contractor shall have a minimum of 5 years of history and experience with excavation support systems and shall have constructed a minimum of three projects more than 20 feet deep. The shaft excavation and support superintendent must have a minimum of 3 years of experience as a superintendent of projects of similar scope.
- B. The excavation support system designer must be a Professional Engineer registered in the State of Oregon who has a minimum of 5 years of experience in the design of excavation support systems.
- C. Tolerances:
  - 1. Location of the excavation supports is within 3 inches of that shown on the working drawings.
  - 2. No portion of the excavation support system element extends beyond the temporary construction easement limits indicated on the Drawings.
  - 3. Verticality of sheet piles or soldier piles is within 1.5 percent of the total height of the wall.
- D. Provide for contingencies as follows:



1. Monitor performance of support system components, for both vertical and horizontal movement as required in paragraph 3.1.A.
2. Provide a contingency plan for alternative procedures to be implemented if the support system does not perform as specified herein and as defined in the submitted calculations or if the ground water control system does not perform to expectations.
3. Keep on hand materials and equipment necessary to implement the contingency plan.

## **1.5 SUMMARY OF GROUND CONDITIONS**

- A. The subsurface soil and groundwater conditions are summarized in the Geotechnical Data Report (GDR) for the project which is included as a Reference Document.
- B. Locations of existing facilities, structures, underground utilities, and systems shown on the Drawings are approximate. Field verify exact location and nature of utilities, structures, facilities, and systems prior to excavation.

## **1.6 DESIGN CRITERIA**

- A. General:
  1. Size the shaft excavation as required to allow for construction of the indicated facilities within the tolerances and limits specified and in consideration of the following:
    - a. Fabricated dimensions of the initial support system subject to the requirements of Section 33 05 23.16, Trenchless Construction including tolerances and clearances.
    - b. Minimum dimensions and clearance requirements related to the means and methods for performing the work.
  2. Design shaft excavation support systems and working slabs to withstand earth pressures, hydrostatic pressures, bottom heave, equipment loads, applicable traffic and construction loads, and other surcharge loads to allow the safe construction of the trenchless crossing while maintaining settlement of the ground surface, roadways, and utilities below limits specified in Section 31 09 00, Instrumentation and Monitoring. The design lateral earth pressures for temporary excavation support are shown on the Drawings. Design excavation support systems to be compatible with the earth pressures included in the Drawings, and the geologic conditions presented in GDR in accordance with AISC and ACI code provisions, as applicable.
  3. Acceptable excavation support methods include the use of steel sheet piling, soldier piles and lagging, structural steel wales and struts, or equivalent systems, as appropriate for the ground conditions. Tieback or soil nail systems are not acceptable excavation support methods.

4. Provide construction stage loadings, as applicable, for a staged removal of the ground support system that conforms to the pipe, structure placement, and backfill indicated. Consider provisions for future construction, and limits on bracing level elevations.
5. Design each member or support element to support the maximum loads that can occur during construction with appropriate safety factors.
6. Employ wales, struts, and beams for bracing and lateral support as required for excavation. Provide struts with intermediate vertical and horizontal supports as required to prevent buckling.
7. Provide a groundwater control system for each shaft in accordance with Section 31 23 19, Dewatering.
8. Design break out framing and suitable launching seals, ground improvement and/or ground treatment provisions, as applicable, to maintain excavation support and to prevent groundwater inflow or loss of ground when breaking out of or into shaft excavations.
9. Design a working slab for each shaft bottom to provide stable support for construction operations and to resist hydrostatic uplift, as applicable.
10. Locate shafts at the locations shown and as required to construct the pipeline between the stations indicated on the Drawings.

## **PART 2 - PRODUCTS**

### **2.1 MATERIALS**

- A. Use steel sheet piling that is continuous interlocking type ASTM A328 of appropriate shape and provided with at least one 2-1/2-inch-diameter handling hole on the centerline of the web located at least 6 inches from each end of the sheet pile.
- B. Use fabricated connections and accessories, steel H-piles, WF shapes, and other structural steel that conform to the requirements of ASTM A36, unless otherwise approved.
- C. Use concrete satisfying the requirements of Section 00540 – Structural Concrete, of the Oregon Standard Specifications for Construction.
  1. Shoring elements:
    - a. Use lean concrete for encasement of steel H-piles in predrilled holes below the final level of excavation.
    - b. Use a concrete mix with one sack of cement per cubic yard of concrete for encasement of steel H-piles above the final level of excavation.
- D. Use dimensional lumber with minimum allowable stress of 1,100 psi for wood lagging.

1. Provide lagging with the stress grade in conformance with the allowable stresses of the IBC. If lagging is to remain in place, use treated lumber in accordance with AASHTO M133.
  2. Use lumber that is grade marked by WWPA or WCLIB with species and grade conforming to those shown on approved shop drawings.
  3. Limit deflections in wood lagging to  $L/600$ .
- E. Use steel lagging per ASTM A-36 with minimum plate dimensions of 1-inch thickness. Allowable deflection in lagging is limited to  $L/600$ .
- F. Use granular shaft backfill materials meeting the requirements of Section 31 23 00, Earthwork.

## **PART 3 - EXECUTION**

### **3.1 CONSTRUCTION**

#### **A. General**

1. Employ methods of construction for shafts that ensure the safety of the work, the construction workers, the public, and adjacent property and improvements, whether public or private.
2. Adequately protect existing structures, utilities, trees, shrubs, and other existing facilities. Repair damage to existing facilities.
3. Protect temporary facilities, until they are no longer required, and when temporary supports and other protective means are no longer required, remove and dispose of as specified.
4. Do not exceed 3 feet of unsupported sidewall soil height.
5. Install excavation support systems in accordance with design requirements. Do not proceed with excavation to the next level until bracing has been installed and tightly blocked or shimmed to provide proper support of the excavation.
6. Monitor performance of excavation support system for both horizontal and vertical deflections daily during excavation, and at intervals not to exceed 7 days following the completion of excavation work. If monitoring data indicates that deflections have exceeded estimated values, or if displacement rate is increasing, increase frequency of monitoring as required by the Owner's Representative. Prepare and implement a plan to stiffen the shoring system that will not exceed the allowable deflections.
7. Monitor overhead clearance envelope in vicinity of power lines.

#### **B. Groundwater and Surface Water Control**

1. Control groundwater for shaft excavations where groundwater is anticipated to be encountered in accordance with Section 31 23 19, Dewatering.

### C. Excavation

1. Complete all excavations regardless of the type, nature, or condition of the materials encountered. Use hand methods for excavation that cannot be accomplished with mechanical excavation equipment without endangering existing or new structures or other facilities.
2. Excavation includes all excavating, moving, hauling, and disposal, including but not limited to, existing pavements, walks, driveways, surfacing, slabs, curbs, gutters, and similar cement concrete structures, bituminous materials, all rock or gravel road surfacing materials, abandoned sewers, and other pipes and conduits, logs, piling, footings, foundations, vaults, and chambers, when such materials are within the limits of excavation for the Work.
3. In removing pavements, curbs, driveways, and similar structures, make cuts where an abutting structure or a part of a structure is to be left in place. Make the cuts clean, smooth, and vertical.
4. When the precise location of subsurface utilities or structures is unknown, locate such structures by hand excavation prior to utilizing mechanical excavation, drilling, augering, or boring equipment.

## 3.2 INSTALLATION

### A. Soldier Piles and Lagging:

1. Install soldier piles to the tip elevations shown in the approved working drawings.
2. Excessive vibration during the soldier pile installation and extraction shall not be permitted if vibration methods are used. Settlement points shall be monitored during installation to confirm that no settlement occurs due to pile installation and extraction. The Contractor is solely responsible for the settlement and damage of the adjacent existing facilities from installation, operation, and extraction of the shoring system.
3. If predrilled piles are used, encase pile with concrete from the tip to the bottom of the final excavation after a pile has been seated plumb in the drill hole.
4. Install lagging and steel sheeting with no gap unless specifically approved. At no time shall there be more than 3 feet of unsupported ground.
5. As installation progresses, backfill the voids between the excavation soil face and the lagging or sheeting with grout or sand. Use materials such as hay or burlap where necessary to allow drainage of groundwater without loss of soil or packing material.
6. If unstable material is encountered, take suitable measures to retain it in place or to otherwise prevent soil displacement.

7. Perform dewatering as needed as specified in Section 31 23 19, Dewatering, prior to excavation for sheeting and lagging.
8. Do not exceed 15 inches of exposed excavated face below the last-placed lagging. Extend lagging down to excavation subgrade.
9. Keep a sufficient quantity of material on hand for sheeting, shoring, bracing, and other operations for protection of work and for use in case of accident or emergency.

B. Steel Sheet Piling:

1. Install steel sheet piling in plumb position with each pile interlocked with adjoining piles for its entire length so as to form a continuous diaphragm throughout the length of each run of wall, bearing tightly against original ground. Install sheeting to depth shown in the approved shop drawings.
2. Exercise care during installation so that interlocking members can be extracted, if required, without damage to adjacent ground.
3. Provide installation equipment that is suitable for the type and nature of the subsurface materials anticipated to be encountered. Use equipment, and methods of installation, cutting, and splicing that conform to the approved shop drawings.
4. Excessive vibration during the sheet pile installation and extraction shall not be permitted. Settlement points shall be monitored during installation to confirm that no settlement occurs due to sheet pile installation and extraction. The Contractor is solely responsible for the settlement and damage of the adjacent existing facilities from installation, operation, and extraction of the shoring system.

C. Internal Bracing Support System:

1. Install all bracing support members and maintain in tight contact with each other and with the surface being supported.
2. Preload bracing members with jacking struts and shores in accordance with loads, methods, procedures, and sequence as described on the approved shop drawings. Coordinate excavation work with bracing installation and preloading. Use steel shims and steel wedges welded or bolted in place to maintain the preloading force in the bracing after release of the jacking equipment pressure. Use procedures so as to produce uniform bracing member loading without appreciable eccentricities, overstressing, or support member distortion. Provide suitable steel spacers/shims where required to fill any gaps between the walers and sheet piling.
3. Provide struts with intermediate bracing as needed to enable them to carry their maximum design load without distortion or buckling. Provide diagonal bracing as necessary to maintain the stability of the system. Provide web stiffeners, plates, or angles as needed to prevent rotation, crippling, or buckling of connectors at points of bearing between

structural steel members. Allow for eccentricities resulting from field fabrication and assembly.

4. Use walers in conjunction with struts to transfer lateral pressure from walers to the struts.
5. Bolt or weld all connections between bracing elements and to the walls. Do not use connections that rely on friction between the elements.
6. Construct excavations to a depth no more than 3 feet below the elevation of the support member about to be placed.

### **3.3 SHAFT BACKFILL**

- A. Place granular shaft backfill material in accordance with Section 31 23 00 - Earthwork.

### **3.4 REMOVAL OF SUPPORT SYSTEM**

- A. All shoring elements, including sheet piles, walers, struts, lagging, and sheeting must be removed or cut off a minimum of 5 feet below the ground surface.
- B. Removal of the support system shall be performed in a manner that will not disturb or harm adjacent construction facilities or the installed casing or pipeline. All voids created by the removal of the support system shall be immediately filled with granular shaft backfill, grout, or lean concrete as approved by the Owner's Representative.
- C. The support system removed from the excavation will remain the property of the Contractor and shall be removed from the site.

**END OF SECTION**

This page intentionally left blank.

## **SECTION 33 05 23.16**

### **TRENCHLESS CONSTRUCTION**

#### **PART 1 - GENERAL**

##### **1.1 SUMMARY**

- A. This Section includes requirements for trenchless construction methods to construct the pipeline at the SW Day Road trenchless crossing.
- B. The Contractor shall furnish and install a jacked steel casing pipe as shown on the Drawings, complete and in place, and in accordance with the requirements of the Contract Documents. Carrier pipe installation within the steel casing shall be in accordance with the requirements contained within this Section.
- C. The Contractor shall select means and methods for trenchless construction in accordance with the requirements within this Section.

##### **1.2 REFERENCES**

- A. Occupational Safety and Health Administration (OSHA) Regulations and Standards for Underground Construction – 29 CFR Part 1926, Subpart Section 1926.800.
- B. Oregon Occupational Safety and Health Code, Oregon Administrative Rules, Chapter 437, Division 3, Construction, Subdivision S – Underground Construction, Caissons, Cofferdams, and Compressed Air, Oregon Occupational Safety and Health Division (OR-OSHA).
- C. American Society for Testing and Materials (ASTM): A36 – Standard Specification for Carbon Structural Steel.
- D. American Welding Society (AWS): D1.1 – Structural Welding Code.

##### **1.3 DEFINITIONS**

- A. Auger Boring: A trenchless technique that consists of jacking a casing through the ground while a cutting head and augers within the casing remove spoils from the excavation face.
- B. Backfill Grouting: Injection of cementitious grout to completely fill the annular space between the carrier pipe and casing pipe.
- C. Casing Pipe: Steel pipe installed within which the carrier pipe is placed. Also referred to as casing.
- D. Carrier Pipe: Service pipeline placed within casing pipe.
- E. Contact Grouting: Injecting grout to fill the annular void outside the jacked casing pipe.
- F. Flowing Ground: Material that advances like a viscous fluid into the heading when left unsupported. In tunnels below the groundwater table, when seepage develops at the working face, raveling or running ground is transformed into



flowing ground. Silt, sand, and gravel below the groundwater table without significant cohesion will exhibit flowing ground behavior.

- G. Obstruction: An object or feature that lies completely or partially within the excavation and prevents forward movement of the shield or machine.
- H. Pipe Jacking: A tunneling technique that involves installing a casing by jacking it into place from a jacking pit or shaft, using hydraulic jacks. Excavation is carried out within a shield in front of the lead casing segment using hand-mining or mechanical methods, or with mechanized equipment such as a tunnel boring machine.
- I. Raveling Ground: Material that breaks up into chunks, flakes, or angular fragments when left unsupported. This process is time-dependent, and materials may be classified by the rate of disintegration as fast or slow raveling. In *fast raveling* ground, the process starts within a few minutes; otherwise, the ground is *slow raveling*. For a material to be raveling, it must be moderately coherent and friable, or discontinuous. Materials exhibiting this behavior include fine moist sand; sands and gravels with clay binder; stiff, fissured clays; friable (weak) rocks; and jointed rocks.
- J. Running Ground: Material that will invade the tunnel until a stable slope is formed at the tunnel face when left unsupported. Stand-up time is zero or nearly zero. Running ground consists of dry, granular materials such as clean, medium to coarse sands and gravels above the groundwater level. Materials intermediate between running and raveling are described as *cohesive running*.

#### 1.4 SUMMARY OF GROUND CONDITIONS

- A. The subsurface soil and groundwater conditions are summarized in the Geotechnical Data Report (GDR) for the project which is included as a Reference Document.
- B. The trenchless crossing will be completed in Fine-Grained Missoula Flood Deposit material consisting of soft to stiff high plasticity, sandy silt to lean clay with sand. Perched groundwater will be encountered within the Missoula Flood Deposits and levels are expected to vary seasonally with changes in precipitation, resulting in groundwater highs occurring in spring and lows occurring in the early- to mid-fall season.
- C. Within the Missoula Flood Deposits, firm to raveling ground conditions will be occur above the groundwater level and fast raveling to flowing ground conditions will occur where groundwater is encountered.

#### 1.5 DESIGN CRITERIA

- A. The construction means and methods selected by the Contractor must be capable of excavating the full range of ground conditions and ground behaviors and control loss of ground.
- B. System Description

1. The trenchless equipment shall be capable of line and grade required to install carrier pipe to the line and grade shown in the Drawings.
2. The trenchless equipment shall consist of a system with sufficient power so that the shield or machine is capable of performing in the ground conditions indicated in the GDR and over the length of tunnel indicated in the Drawings.
3. The trenchless equipment shall be a continuous full-circle (360-degree) device suitable for the Work, with a uniform exterior surface from the leading edge to the trailing edge.
4. The maximum allowable overcut of the trenchless equipment shall not be greater than 1 inch larger in diameter than the outside diameter of the casing pipe.
5. The system shall have an external contact grouting capability to inject contact grout at the completion of the drive.
6. Equipment shall have the capability of providing breasting or other measures for fully supporting face of excavation to prevent ground loss during mining and shutdown periods.
7. The system must control ground surface settlement or heave to limits specified in Section 31 09 00, Instrumentation and Monitoring or less.
8. The selection of muck handling systems shall consider the disturbed behavior of excavated material and water.
9. Design the connection between the tail of the shield or machine to the steel casing pipe to prevent soil, lubrication, and water from moving into the tunnel through the joint.

C. Jacking System:

1. The jacking system shall be capable of continuously monitoring the jacking pressure, the rate of advancement, and the distance jacked.
2. Develop the jacking system with a uniform distribution of jacking forces on the end of the pipe. Use fire resistant hydraulic fluids.
3. Thrust Reaction Backstop:
  - a. Designed to support the maximum anticipated jacking load with a minimum factor of safety of 2.0.
  - b. Square with proposed pipe alignment and remain square throughout the jacking operation.

D. Casing Pipe: Casing pipe shall meet the requirements of Section 33 05 23.20, Steel Casing Pipe.

E. Design a casing spacer system that fully supports the carrier pipe; protects the pipe from flotation, movement, and damage during backfill grouting; electrically isolates the carrier pipe from the casing pipe; and allows for installation of the carrier pipe in accordance with specified tolerances. Design

casing spacers to support the weight of the carrier pipeline filled with water. Maximum casing spacer spacing shall be per the manufacturer recommendations and in no case shall there be less than 2 casing spacers per pipe section.

F. Contact Grout:

1. Neat cement grout with a proportion of 1:1 (by volume).

G. Backfill Grout:

1. Proportion of fine aggregate to cement ratio by weight shall not exceed 5:1.
2. Volume of water shall be as required to produce a flowable, pumpable consistency that will completely fill the annular space between carrier pipe, casing spacers, and casing pipe.
3. Achieve a minimum 28-day compressive strength of 300 pounds per square inch (psi).

H. Tolerances:

1. The casing pipe shall be installed to allow the carrier pipe to be installed at the designed line and grade within the required tolerances while maintaining a minimum annular backfill thickness of 3-inches.
2. The following tolerances apply to the installation of the carrier pipe:
  - a. Horizontal Line Tolerance: 2 inches.
  - b. Vertical Grade Tolerance: 2 inches.
3. No reverse grading or pooling of water shall be allowed within the carrier pipe.

## 1.6 SUBMITTALS

- A. Provide the qualifications of the contractor, project superintendent, and pipe jacking operator responsible for constructing the trenchless crossing. Include a list of past trenchless construction projects during the past 5 years showing: date of work, location, project name, owner, ground conditions, and trenchless methods utilized. Minimum experience requirements are described in paragraph 1.7.
- B. Provide the qualifications of the Professional Engineer responsible for the calculations required for the trenchless crossing herein. Include a list of past trenchless projects during the past 5 years where they were responsible for the trenchless calculations showing: date of work, location, project name, owner, ground conditions, and trenchless methods utilized.
- C. Provide the qualifications of the Professional Land Surveyor. Include a list of past trenchless construction projects during the past 5 years showing: date of work, location, project name, owner, and trenchless methods utilized.

- D. Working Drawings: The Contractor shall submit working drawings for all fabricated materials including the following:
1. Casing pipe dimensions, wall thickness, location of grout ports, grout port and plug details as applicable for each type of steel pipe.
  2. Casing spacer dimensions and details.
- E. Working Drawings and Methods Statements:
1. Trenchless Plan:
    - a. Trenchless Plan shall be submitted not less than 30 days before any work relating to the trenchless operation is commenced. No excavation for trenchless operations shall be undertaken until receipt of the Owner's written acceptance of the plan.
    - b. Details of the tunneling machine or shield type including dimensions, weight, power and torque capabilities, rotational capabilities, and configuration of cutterhead, as applicable.
    - c. Detailed plans of the methods and procedures to be utilized to complete the Work. Include descriptions of trenchless construction operations, details of jacking system, and jacking reaction block.
    - d. Description of specific shield or machine capabilities for maintaining a stable tunnel heading and minimizing ground loss.
    - e. Description of methods and capabilities for controlling ground conditions and preventing loss of ground at the tunnel heading during launch, during tunnel excavation, and during reception.
    - f. Casing pipe installation schedules which include schedules of excavation, welding, contact grouting, carrier pipe installation, and backfill operations.
    - g. Details related to field welding of steel casing. Include shop drawing, procedures, welders' licenses, and welding schedule.
    - h. Locations, sizes and design of jacking and receiving pits. Jacking and receiving pits shall be in accordance with Section 31 41 00, Shaft Excavation and Support.
    - i. Detailed description of ventilation and lighting.
    - j. Description of the guidance, alignment control, and steering systems, including a description of the surveying methods to set laser positions, a description of procedures to check laser, and a description to reset or realign laser during construction.
    - k. Details of casing lubrication system and description of lubricants to be used during pipe jacking, including manufacturer's literature.
    - l. Spoils handling operations plan including mucking systems and muck handling and transportation equipment used to convey muck out of the casing.

- m. Information defining the proposed jacking system including:
    - 1) Capacity, number, and arrangement of jacks.
    - 2) Details of thrust ring, jacking controls, pressure gages, and calibration data for jacks indicating pressure versus load relationship.
  - n. Calculations stamped and signed by a Professional Engineer licensed in the State of Oregon:
    - 1) An estimate of the maximum jacking force expected to be required to complete the drive.
    - 2) The thrust resistance for the shaft wall and calculated shaft wall deflection at maximum thrust. Coordinate with shaft design and related shaft submittals.
  - o. Details of methods, procedures, proposed pressures, grout mix design, and equipment for contact grouting to fill voids and displace any lubricant outside the casing. Indicate closure criteria for each grout port hook up.
  - p. Line and grade calculations and layout for casing pipe installation.
2. Carrier Pipe Installation Plan:
- a. Installation of carrier pipe including sequence and methods for installing, supporting, and blocking the pipe in the casing pipe.
  - b. Methods, procedures, and equipment for backfill grouting including proportioning, mixing, batching, and delivery. Describe procedures to completely fill voids between carrier pipe and casing.
  - c. Details on casing spacer system, materials, dimensions and installation procedures and recommendations.
  - d. Backfill grout mix design.
  - e. Calculations stamped, dated, and signed by a Professional Engineer licensed by the State of Oregon for:
    - 1) Backfill grout pressure limits.
    - 2) Maximum grout lift height.
    - 3) Pipe flotation forces.
    - 4) Bulkhead design.
3. Safety plan for personnel conducting the tunnel or jacking operations and appurtenance installation.
4. Respiratory Protection and Exposure Monitoring Plan for welders.
5. Contingency Plan: Provide a work plan that as a minimum addresses the following items:

- a. Loss of face control and/or excessive ground loss.
  - b. Inflow of water beyond 5 gallons per minute.
  - c. The casing pipe hits an obstruction.
  - d. The drive is not completed and 80 percent of the maximum allowable jacking forces has been attained.
- F. Recordkeeping:
1. Daily log: During trenchless installation operations, the Contractor shall submit a daily log including jacking forces, pipe position in relation to line and grade, lubrication volume, pumping pressure, volume of muck, problems with equipment, durations and reasons for delays, etc.
  2. Contact grout and backfill grout reports and records: Maintain and submit daily logs of grouting operations, including grouting locations, pressures, volumes, and grout mix pumped, and time of pumping. Note any problems or unusual observations on logs.
- G. Surface monitoring data in accordance with Section 31 09 00, Instrumentation and Monitoring.

## 1.7 QUALITY CONTROL

- A. Contractor Qualifications: Submit written documentation as supporting evidence of the qualifications of the trenchless installation contractor, its superintendent, and equipment operator.
1. Contractor shall have a minimum of 5 years of successful experience with trenchless construction in soil at similar diameters, at similar depths, with comparable equipment. Provide owner references names, addresses, and telephone numbers. The Contractor must have completed at least 3 trenchless projects with a minimum diameter of 60 inches in diameter in the last 5 years.
  2. The actual work shall at all times be performed under the direct supervision of an approved, experienced Project Superintendent with at least 5 years recent on-the-job supervision experience on similar projects. The Project Superintendent must have completed at least 3 projects involving trenchless construction with a minimum diameter of 60 inches constructed by similar methods.
  3. Each pipe-jacking operator shall have at least 5 years continuous demonstrated experience as pipe jacking operator with comparable equipment in similar ground conditions.
  4. All pipe-jacking operators and superintendents shall read the Geotechnical Data Report to familiarize themselves with the geotechnical conditions to develop their means and methods to suit the project geologic conditions.

5. Key personnel operating and maintaining pipe-jacking equipment, including the guidance system, and pipe-jacking equipment, must have received training from the manufacturers. Proof of training (i.e., certification from manufacturer) shall be provided.
- B. Professional Engineer qualifications: The engineer responsible for the support calculations of the trenchless crossing shall be a Professional Licensed Engineer in the State of Oregon who has a minimum of 5 years of experience in the design of trenchless crossings.
  - C. Professional Land Surveyor qualifications: The surveyor responsible for line and grade control of the trenchless installation shall be a Professional Licensed Surveyor registered in the State of Oregon who has prior experience in surveying line and grade of pipe in similar underground projects.
  - D. The Contractor shall give the Owner's Representative a minimum of 7 days advance notice of the start of an excavation or pipe-jacking operations.
  - E. All welding procedures used to fabricate steel casings shall be prequalified under the provisions of ANSI/AWS D1.1. Welding procedures shall be required for, but not necessarily limited to, longitudinal and girth or special welds for pipe cylinders, casing joint welds, reinforcing plates and grout coupling connections.
  - F. Notify existing utilities. Before commencing construction activities near existing natural gas, petroleum pipelines, and water mains, contact representatives from each utility and schedule potholing, excavation, jacking, and boring activities so representatives from utility owners can be on site if required. No construction activity related to jacking or boring operations including but not limited to potholing, excavation, stockpiling materials, or tunneling shall occur without written permission from utility owners.
  - G. Pothole all utilities that may cross the alignment or that may be located within 10 feet of jacking or receiving pits and all other excavations associated with trenchless construction operations using vacuum extraction methods to reduce damage potential to the utility. Potholes shall identify type, depth, location, and size of utilities. Notify utility owner and abide by their requirements before and during potholing operations.
  - H. Prior to contact grouting, verify calibration of flow meter, and pressure gauges.
  - I. Backfill Grout Testing:
    1. The Owner or Owner's Representative shall perform testing of grout samples during backfill grout placement between the carrier pipe and casing pipe.
    2. A minimum of one set of four 4-inch by 8-inch grout samples for compressive strength testing per 50 cubic yards of grout placed, or one set for each day grout is placed.
    3. Perform compressive strength testing at 7 days (one test) and 28 days (two tests). Perform tests following ASTM C39.

## **1.8 DELIVERY, HANDLING, AND STORAGE**

- A. Casing pipe or carrier pipe delivered with visible damage shall not be used. Damaged or defective pipe shall be marked with a permanent marking as rejected and shall be promptly removed from the job site.
- B. Permalok connections shall be examined at the time of shipment and shall be free of injurious defects or that section shall be rejected and repaired prior to shipping.
- C. Use proper tools and equipment to handle pipe. Slings shall be made of rope, nonmetallic webbing, or other materials that will not damage the pipe. Chain or cable slings or chokers shall not be used to handle the pipe. Lifting eyes, if used, shall be constructed to provide uniform bearing along the top of the pipe. Lifting eyes shall be used only when approved by the pipe manufacturer.

## **PART 2 - PRODUCTS**

### **2.1 EQUIPMENT**

- A. Pipe Jacking Equipment:
  - 1. Meet the minimum requirements identified in paragraph 1.5.
- B. Grouting Equipment:
  - 1. Equipment for mixing and injecting contact grout shall be adequate to satisfactorily mix and agitate the grout and force it into the ports, as required, in a continuous flow at the desired pressure.
  - 2. Pumps shall be capable of continuously developing a sustained pressure at the grout port connection.
  - 3. Two pressure gauges shall be provided, one at the grout pump and one at the collar of each port being grouted. The accuracy of the gauges shall be periodically checked with a calibrated pressure gauge. An adequate supply of spare pressure gauges shall be onsite at all times.
  - 4. Suitable stop valves shall be provided at the collar of each port for use in maintaining pressure as required, until the grout has set.
  - 5. The grouting equipment shall be provided with a meter to determine the volume of grout injected. The meter shall be calibrated in cubic feet to the nearest one-tenth of a cubic foot.
  - 6. The grouting equipment shall be maintained in satisfactory operating condition throughout the course of the work to ensure continuous and efficient performance of grouting operations.

### **2.2 MATERIALS**

- A. Steel Casing Pipe: Provide casing pipe in accordance with Section 33 05 23.20, Steel Casing Pipe



- B. Bentonite: Bentonite shall be a commercial-processed powdered bentonite, Wyoming type, such as Imacco-gel, Black Hills, or equal.
- C. Grout materials shall conform to the following requirements:
  - 1. Grout will contain water, Portland cement (Type II, meeting ASTM C150), and various amounts of sand, flyash, and other admixtures based on the application.
  - 2. Ingredients of grout mix are to be noncorrosive to steel and free from calcium chloride.
- D. Lubricant: Lubricant shall be a refined and processed natural high swelling montmorillonite clay (Bentonite slurry) or other product as approved by the Owner as necessary to produce satisfactory lubrication and earth support. Lubricant shall conform to NSF/ANSI Standard 61.
- E. Carrier Pipe: Carrier pipe shall conform to Section 40 20 13, Steel Pipe (AWWA C200, Modified) for Steel Transmission Pipe.
- F. Casing Spacers: Casing spacers shall satisfy the design requirements as specified herein.

### **PART 3 - EXECUTION**

#### **3.1 GENERAL REQUIREMENTS**

- A. Do not begin pipe jacking until the following conditions have been met:
  - 1. Required submittals have been made and the Owner's Representative has completed review and accepted all submittals.
  - 2. A pre-job safety conference has been conducted. Arrange this conference and inform the Owner's Representative of the time and place of the conference not less than 7 working days in advance.
  - 3. Baseline instrumentation readings have been taken and documented.
- B. Shaft construction shall be constructed in accordance with the requirements of Section 31 41 00, Shaft Excavation and Support.
- C. Dewatering shall be in accordance with Section 31 23 19, Dewatering.
- D. Install casing pipe between the limits indicated on the Drawings to the specified lines and grades. Utilize methods that include due regard for safety of workers, adjacent facilities, structures, utilities, and the public.
- E. Conform to all settlement restrictions per Section 31 09 00, Instrumentation and Monitoring and the additional measure defined below:
  - 1. Coordinate with such instrumentation monitoring activities. Make probes, sensors, and readout devices available as required.
  - 2. Temporarily cease activities that create hazards to instrument monitoring or surveying personnel.

3. Instrumentation will be monitored more frequently if the measurements detect significant, anomalous, or suddenly changing deformations, loads or hydrostatic pressures.
4. Be available to discuss the interpretation of instrumentation data as used in evaluating tunneling and shaft excavation performance and controlling settlements to prevent damage to structures, facilities, and utilities.

### **3.2 WORK AREA PREPARATION AND MAINTENANCE**

- A. The Contractor shall be responsible for means and methods of trenchless construction operations and shall ensure the safety of the work, the Contractor's employees, the public, and adjacent property, whether public or private. The Contractor equipment shall comply with all local noise ordinances.
- B. Maintain clean working conditions inside the trenchless construction operation area and remove spoil, debris, equipment, and other material not required for operations. No pipe shall be stored on any city street unless permission is granted in writing by the Owner. Streets shall be cleaned each day with a water truck or street sweeper.
- C. Trenchless construction surface equipment shall be organized for each drive in such a manner as to enable proper operation at all times, to minimize impacts to property owners, and to maintain traffic control patterns shown on the traffic control drawings and specified in the Contract Documents.
- D. Power generation equipment and all other equipment operating on or with fuel or lubrication oils shall be provided with suitable oil and gas containment basins made of plastic lining and sand bags to ensure no loss of oil to drains or water courses or to contaminate the ground.
- E. All equipment shall be maintained and kept in proper repair. All oil, hydraulic, or fuel leaks shall be repaired immediately. All leaks shall be cleaned up immediately and disposed of properly.
- F. Verify locations of existing underground utilities by potholing in areas where equipment or materials may be parked or stored. Do not park equipment or store materials on top of existing underground utilities.

### **3.3 TEMPORARY VENTILATION**

- A. When personnel are underground, furnish and operate a temporary ventilation system, and air monitoring system conforming to the requirements of OSHA. Operate and maintain a ventilation system that provides a sufficient supply of fresh air and maintains an atmosphere free of toxic or flammable gasses in the tunnel. Perform air quality monitoring checks at the start of each shift, before any personnel enter a shaft or pit, and provide continuous monitoring within the tunnel at all times personnel are inside the tunnel.

### 3.4 CASING INSTALLATION

- A. Complete pipe installation in accordance with the approved submittals. Use trenchless construction methods complying with the requirements specified herein.
- B. Prior to trenchless construction operations, survey the location and orientation of the pipe guide rails and jacking frame to ensure they are on the proper line and grade.
- C. Inspect all casing pipe prior to lowering into the jacking pit to ensure that no defective materials are being used. Clean ends of pipe thoroughly. Remove foreign matter and dirt from pipe joints during laying.
- D. Distribute axial forces from the thrust jacks to the casing pipe uniformly through cushion material to prevent damage to the ends of the pipe.
- E. Weld or join each casing joint completely prior to jacking.
- F. Jack each casing pipe section as the excavation progresses in such a way that leaves no length of ground unsupported at any time.
- G. Perform trenchless construction operations in a manner that will maintain the stability of the heading and prevent loss of ground and minimize settlement of the ground surface. Use steering to maintain line and grade within the tolerance specified.
- H. Provide groundwater control as required for proper execution of the Work.
- I. Remove, clear, or otherwise make it possible for the jacked casing to advance past objects or natural materials consisting of cobbles, boulders, mixed face conditions, and other objects or debris that halt forward progress of the shield or machine.
- J. Utilize a casing lubrication system as necessary to inject bentonite slurry and/or polymer behind the shield and through casing grout ports and in quantities as required to maintain jacking forces to acceptable levels.
- K. As a minimum, monitor and record at 5-foot intervals, the thrust force, rate of advance, distance along the drive, deviation from line and grade, and steering jack adjustments for each casing segment installed.
- L. The Contractor shall take special care during the installation of the casing pipe to minimize caving, settlement, or heave of above surfaces. The Contractor shall maintain close observation of the above surfaces and shall be prepared to contact the Owner if settlement, caving, or heave is detected. All damage resulting from settlement, caving, or heave shall be repaired at the Contractor's expense with no additional cost to the Owner. The Contractor shall coordinate and arrange for all such repairs as required.
- M. Whenever jacking is stopped for maintenance or at the end of a shift, provide necessary means to ensure heading stability. Wherever there is a condition which, in the opinion of the Owner's Representative, may endanger the stability of the excavation or adjacent utilities, the Contractor shall operate

with a full crew for 24 hours a day, including weekends and holidays, without intermission until those conditions no longer jeopardize the stability of the work.

- N. Implement appropriate contingency plans as necessary and notify the Owner's Representative in writing immediately upon implementation of any contingency plan.
- O. Muck Disposal:
  1. Dispose of all muck and excess material offsite and in compliance with applicable state and local regulations.
  2. The Contractor shall be responsible for locating and acquiring a site for the legal disposal of muck and excess excavated material.
  3. Muck or excess material shall not be discharged into any surface ditch, waterway, storm drain, sanitary sewer or any other such conveyance.

### **3.5 CONTROL OF LINE AND GRADE**

- A. Monitor line and grade continuously during pipe-jacking operations. Control line and grade of the pipe to within the specified tolerances.
- B. When the excavation is offline or grade, make the necessary corrections, and return to the plan alignment at a rate that does not damage the casing or causes the casing to exceed installation tolerances.
- C. Perform a verification survey with transit or total station of the installed casing pipe from shaft to shaft after removal of the pipe-jacking equipment. Document measured conformance to design line and grade of the casing pipe together with locations and deviation (distance or direction) of all out-of-tolerance locations.

### **3.6 CONTACT GROUTING**

- A. Immediately after completion of the pipe-jacking operations, the Contractor shall contact grout through the grout ports in such a manner as to displace the lubricant and completely fill all voids outside the casing pipe resulting from the jacking operations. Regardless of whether or not grout return is observed from an adjacent grout port, the Contractor should hook up to each grout port and attempt to contact grout.
- B. Perform grouting in a progressive, methodical manner. Work from the low end of the tunnel and work towards the opposite end.
- C. Grout pressure shall be sufficient to displace the lubricant and controlled so as to avoid deformation of the steel casing and avoid movement of the surrounding ground.
- D. After completion of the grouting operations, the Contractor shall close the grout ports with threaded plugs.

### 3.7 OBSTRUCTIONS DURING PIPE JACKING

- A. Remove, clear or otherwise make it possible for the pipe-jacking system and casing pipe to progress past through objects in accordance with the Contractor's submitted contingency plan.
- B. The Contractor shall not receive additional compensation for removing, clearing, or otherwise making it possible for the pipe-jacking system to progress past objects that are not obstructions.
- C. The Contractor shall receive payment for obstruction removal, if the object meets the definition of an obstruction, and subject to the following requirements:
  - 1. Notify the Owner's Representative immediately upon encountering an object that stops the forward progress of the Work.
  - 2. Upon written authorization by the Owner, proceed with removal of the object by means of obstruction removal procedures in accordance with the Contractor's accepted submittals.
  - 3. No excavation within 5 feet of the front of the leading edge shall be completed without Owner's Representative's knowledge.
- D. The Contractor may propose alternative methods for removing, clearing, or otherwise making it possible for the pipe-jacking system to progress past objects, however, any such method that does not allow visual observation and measurement of the nature of the object to be made will not be considered for additional payment.

### 3.8 INSTALLATION OF CARRIER PIPE

- A. Install carrier pipe as shown on the Drawings in accordance with specified tolerances.
- B. Verify the alignment, grade, deflection, and joint conditions of the casing pipe will not impede installation of carrier pipe.
- C. Provide nonmetallic casing spacers and blocking to provide a straight and even grade at inverts and to prevent flotation, movement, or damage to the pipe during installation.
- D. Push carrier pipe through casing pipe and make each joint as pipe is being inserted. Field joint coating and lining shall be in accordance with Section 40 20 13, Steel Pipe (AWWA C200, Modified).
- E. Joint weld testing of the carrier pipe shall be completed prior to filling of the annular space between the casing and carrier pipe.
- F. Backfill the annular space between casing pipe and carrier pipe with grout. Furnish all materials and equipment necessary for the backfilling operation. Proportion grout to uniformly distribute grout around pipe, spacers and blocking and to completely fill the annular space between the carrier pipe and the casing.

- G. During backfilling, ballast carrier pipe and/or utilize multiple lifts as necessary to prevent flotation and pipe damage during backfill placement, and completely fill the annular space between the casing and carrier pipe.
- H. Design and construct bulkhead at each end of the casing to contain the grout. Provide grout injection ports and venting through bulkheads as necessary to perform the backfilling work.

### **3.9 INSTRUMENTATION AND MONITORING**

- A. The Contractor shall carry out operations to minimize settlement and/or heave of the ground and shall be responsible for all damage due to settlement, consolidation, or heave from all construction induced activities.
- B. Follow the accepted settlement monitoring plan in accordance with Section 31 09 00, Instrumentation and Monitoring.
- C. Prior to pipe jacking, install and maintain a system of instrumentation to monitor the underground excavation operation and to detect movement in the soil and adjacent structures as shown on the Drawings and at additional locations identified by the Contractor, or as approved by the Owner's Representative.
- D. Conduct survey for each settlement monitoring point in accordance with schedule provided in Section 31 09 00, Instrumentation and Monitoring.
- E. In the event of movement of the ground surface or structure being detected or damage recorded, the Owner's Representative may order that the work be stopped and secured. Before proceeding, the Contractor shall correct all problems causing or resulting from such movement entirely at its own cost. If ground settlement or heave occurs, which might affect the accuracy of temporary or permanent benchmarks, it is the Contractor's responsibility to monitor and immediately report such movement to the Owner's Representative.

### **3.10 CLEANUP AND RESTORATION**

- A. Remove all trenchless construction equipment, materials, and waste from the site.
- B. Restore to their original ground condition all existing surface improvements damaged or removed as a result of construction of the work, unless noted otherwise.

**END OF SECTION**

*This page intentionally left blank.*

## **SECTION 33 05 23.20**

### **STEEL CASING PIPE**

#### **PART 1 - GENERAL**

##### **1.1 SUMMARY**

- A. This Section specifies requirements for furnishing and installation of all steel casing pipe as designated in the Contract Documents for use with trenchless construction.
- B. The American Iron and Steel Provisions apply to this project. Refer to Section 01 11 00, Summary of Work.

##### **1.2 REFERENCE STANDARDS**

- A. American Society for Testing and Materials (ASTM):
  - 1. ASTM A36, Standard Specification for Carbon Structural Steel.
  - 2. ASTM A515, Standard Specification for Pressure Vessel Plates, Carbon Steel, for Intermediate- and Higher-Temperature Service.
  - 3. ASTM A572, Standard Specification for High-Strength Low-Alloy Columbium-Vanadium Structural Steel.
- B. American Welding Society (AWS): D1.1 – Structural Welding Code.

##### **1.3 DESIGN CRITERIA**

- A. Casing shall be steel pipe and installed as shown on the Drawings. Welded steel pipe or Permalok casing are acceptable casing pipe materials.
- B. Provide minimum casing pipe inside diameter as shown on the Drawings. Casing pipe must have minimum inside diameter that permits the carrier pipe to be installed to the designed line and grade and provides clearances as specified herein.
- C. Casing wall thickness shall be a minimum of 0.5-inch. Minimum casing pipe thickness has been sized for anticipated earth pressures and live loads. Contractor is responsible for increasing the thickness for installation loads as necessary based on the Contractor's means and methods.
- D. Size wall thickness such that jacking loads do not exceed 50% of the yield stress of the casing.
- E. Casing pipe shall have sufficient straightness and roundness to withstand the installation jacking pressures and maintain line and grade within the specified tolerances.



## 1.4 SUBMITTALS

- A. Certifications: The Contractor shall furnish a certified affidavit of compliance for all pipe and other products or materials furnished under this Section of the Specifications and the following supplemental requirements:
  - 1. Physical and chemical properties of all steel.
  - 2. American Iron and Steel (AIS) step certification letter(s).
  - 3. All expenses incurred in making samples for certification of tests shall be borne by the Contractor.
- B. Drawings and details showing pipe dimensions, wall thickness, location of grout/lubrication ports, port and plug details.
- C. Provide calculations stamped by a Professional Engineer registered in the State of Oregon that demonstrate the casing pipe is capable of sustaining the maximum stresses to be imposed during installation. Provide calculations that consider jacking forces, eccentric forces due to steering, and any other loads that may be reasonably anticipated during construction. Clearly state all load case assumptions.

## 1.5 QUALITY ASSURANCE

- A. Perform all welding using qualified welders who have adequate experience in the type of materials to be used. Employ only welders qualified under the provisions of ANSI/AWS D1.1 by an independent, local, approved testing agency not more than 6 months prior to commencing work on the casing.
- B. All welders shall be either pre-qualified in accordance with ANSI/AWS D 1.1 for full penetration welds, or qualified by testing as required by ANSI/AWS D1.1.

## 1.6 DELIVERY, HANDLING, AND STORAGE

- A. Utilize a sling or other appropriate means to lift and protect the steel casing during handling.
- B. Use dunnage (or 4'x4's) to stage pieces of Pipe. Do not lay the pipe on the ground.
- C. Permalok Pipe:
  - 1. Prevent damage to precision machined connectors.
  - 2. Prior to unloading Permalok casing, carefully inspect each piece visually and note any damage or abnormalities on the carriers bill of lading.
  - 3. Do not hook the Permalok ends of the casing, unless using the special hooks supplied by Permalok. Use wrap-around straps or other methods approved by the Permalok Manufacturer.

## PART 2 - PRODUCTS

### 2.1 MATERIALS

- A. Steel Casing: Pipe shall conform to the requirements of ASTM A36, ASTM A515, grade 60 or ASTM A572, grade 42.
1. Steel casing shall have minimum yield strength of 35,000 psi, and a minimum tensile strength of 60,000 psi. Increase the yield strength or pipe wall thickness as required based on the jacking loads anticipated.
  2. Casing Section Joints:
    - a. Joints are to be butt-welded in the field. Where butt-welded, prepare each end of the casing for butt-welding by providing a 1/4-inch by 45-degree chamfer on the outside edges.
    - b. Permalok joints shall be mechanical press fit type T-5.
    - c. Permalok connectors shall be full penetration butt-welded square to the ends of pipe sections, or profiled directly on the finished sections, at the discretion of the manufacturer.
  3. Provide dimensional tolerances including the following:
    - a. Roundness: Do not allow the pipe diameter as measured along any single plane to vary more than 1% from the specified diameter.
    - b. Circumference: Do not allow the outside circumference to vary more than  $\pm 1\%$  from the nominal circumference based on the specified diameter, or  $\pm 3/4$ -inch maximum
    - c. Wall Thickness: Do not allow the actual wall thickness of the steel pipe sections to vary more than 5% under the nominal wall thickness specified.
    - d. Straightness: The maximum allowable straightness deviation in any 10-foot length is 1/8-inches. The maximum allowable straightness deviation in fabricated section up to 40-feet is 3/8-inches.
  4. The quality control requirements include the following:
    - a. Perform all welding by qualified welding operators in accordance with the requirements of ANSI/AWS D1.1.
    - b. Prequalify all welding procedures by testing, as required.
    - c. Evaluate one reduced section tension test specimen for each lot of 1000-feet of each size and wall thickness, and showing a tensile strength of not less than 95% of the minimum strength specified for the grade of steel used.
    - d. Examine all Permalok connections at time of shipment and verify that it is free of injurious defects or that section will be rejected repaired or replaced prior to shipping.

- e. Clearly mark all casing pipe with the manufacturer's name, manufacturer's job number, customer name, OD, wall thickness, and weight per foot.
5. Grout/Lubrication Ports:
- a. Steel casing shall be furnished with 2-inch minimum diameter grout/lubrication ports, using Schedule 40 pipe (ASTM A53) with threaded plugs.
  - b. Locate ports as shown on the Drawings.

## **PART 3 - EXECUTION**

### **3.1 CONSTRUCTION**

- A. Install the steel casing in accordance with the requirements of Section 33 05 23.16, Trenchless Construction.
- B. For Permalok steel casing, utilize the manufacture's following installation requirements in addition to the requirements of Section 33 05 23.16, Trenchless Construction:
  - 1. Remove the protective coating from end of the pipe prior to mating the Permalok connections, using a petroleum based solvent approved by the pipe manufacturer. Prepare ends by cleaning with firm bristle or wire brush and/or petroleum based solvent. Wipe clean and dry with shop towel or rag. The machined surface must be dry, clean, smooth and free of rust or weld spatter.
  - 2. Apply TRV Silicone to distal end of male and female connectors, making sure that a continuous bead of silicone encircles the circumference and that it cures per manufacturer's recommendations. Spreading or tooling the silicone is optional. Align pipe straight and mate the connectors. Check the joint for complete closure all the way around the circumference.

**END OF SECTION**